

# Mobil Plastic®

*Catalogo Generale*  
**2025**

**Mobil Plastic**

*Catalogo Generale 2025*





# Indice



FERRAMENTA & MAGAZZINO 13  
HARDWARE & STORAGE



PULIZIA &  
RACCOLTA DIFFERENZIATA 67  
CLEANING & WASTE COLLECTION



ENOLOGIA & AGRICOLTURA 97  
ENOLOGY & AGRICULTURE



TRASPORTO LIQUIDI &  
INDUSTRIA ALIMENTARE 111  
LIQUID TRANSPORT & FOOD INDUSTRY



CASALINGHI 137  
HOUSEHOLD

**Mobil Plastic®**

# Dove siamo

**Mobil Plastic®**

**Via Robbio 31, 27030 Confienza (PV) ITALIA**

## **COME RAGGIUNGERCI**

Mobil Plastic s.p.a. è ubicata in località CONFIENZA (PV) a ca. 15 km da Novara, Vercelli e Mortara. In posizione strategica rispetto alle grandi linee di comunicazione, la si può raggiungere sia dalla A4 (Torino – Venezia) uscita Novara Est, che dalla A21 (Piacenza – Torino) uscita Voghera, che dalla A26 (Gravellona – Voltri) uscita Vercelli Est.

## **HOW TO REACH US**

*Mobil Plastic s.p.a. is located in CONFIENZA (PV) about 15 km from Novara, Vercelli and Mortara. In a strategic position with respect to the main transport network, it can be reached either from the A4 (Turin-Venice) Novara Est exit or from the A21 (Piacenza-Turin) Voghera exit or from the A26 (Gravellona-Voltri) Vercelli Est exit.*





# About



## 1968

Verso la fine degli anni '60, gli anni che hanno segnato la storia industriale dell'Italia, e più precisamente nel 1968, viene fondata l'azienda Mobil Plastic.

Fin dai primi anni il successo è stato immediato, prima in Italia, per poi espandersi nei mercati europei di riferimento con la presenza a tutte le Fiere Internazionali più importanti del settore.

In the late '60s and more precisely in 1968, years that marked the industrial history in Italy, Mobil Plastic started its activity. Since the early years, the company has made an instant success, first of all in Italy and then also in the most important European markets, attending all the best known international exhibitions in its sector.



## 1997

Nel pieno della sua continua espansione, nel 1997 avviene il passaggio generazionale alla guida della società. Subentrano infatti i figli del fondatore, Alberto e Pierangelo, i quali fin da subito pongono le basi per una ulteriore crescita applicando una rinnovata politica aziendale unitamente a moderne strategie commerciali.

Nuove ed innovative tecnologie di produzione ed una attenta e mirata ricerca e diversificazione, consentono, pochi anni dopo, l'apertura di una nuova unità produttiva all'estero.

In 1997, in the middle of its continuous expansion, the company generational handover took place.

The founder's sons, Alberto and Pierangelo, chose to follow an updated company policy together with new business strategies. Few years later, thanks to new production technologies, a focused research and diversification approaches, Mobil Plastic started a new production unit abroad.



## 2008

Il 2008 segna una ulteriore ed importante svolta con l'acquisizione di una storica azienda Italiana molto conosciuta con il marchio SSS, attiva da oltre 40 anni nel settore casalingo, enologico, industriale e più di recente anche nel settore ecologico.

L'importante investimento vede raddoppiare le dimensioni aziendali e i volumi di produzione imponendo alla società Mobil Plastic nuovi obiettivi, nuove strategie e nuove sfide commerciali.

2008 marks a further important turning point thanks to the takeover of a well-known Italian company famous for the "SSS" brand, which has worked for more than 40 years in the enology, households, industrial and, more recently, eco-friendly sector.

This important investment doubles the company dimensions and the production volumes, imposing to Mobil Plastic new goals, new strategies and new business challenges.



# 2018

Mobil Plastic compie 50 anni ed è sempre più una realtà leader nel suo settore merceologico. E' affermata in tutta Europa con lo spirito dell'innovazione, di nuovi processi produttivi, del web e dei nuovi mercati; si apre una nuova era e nasce la nuova immagine della società in linea con i tempi. Ancora una volta, Mobil Plastic pone le basi per una ulteriore evoluzione e crescita e si propone al mercato come "partner" serio, affidabile e moderno.

Mobil Plastic celebrates 50 years of activity and nowadays it is a leading company on its market. It is a well-known company all over Europe thanks to its spirit of innovation, its tendency for new production processes, web market and other sectors. This is the beginning of a new era with a contemporary and up-to-date corporate image.



# 2022

Anni difficili, di pandemia che stravolgono le abitudini, i valori e le regole dei mercati in tutto il mondo. Mobil Plastic ancora una volta si distingue per versatilità, resilienza e reattività ai cambiamenti consolidando e crescendo ulteriormente.

Nuovi importanti investimenti in linea con le direttive INDUSTRIA 4.0 e la ricerca e l'utilizzo di nuove tecnologie e processi produttivi con materie prime GREEN a basso impatto. Mobil Plastic guarda al futuro con sano ottimismo, consapevole del proprio know how e pronta ad affrontare ed ad imporsi ai mercati di riferimento in tutta Europa

Difficult years, years of pandemics that upset the habits, values and rules of markets all over the world. Mobil Plastic once again stands out for its versatility, resilience and reactivity to changes, consolidating and growing further.

New important investments in line with the INDUSTRY 4.0 directives and the research and use of new technologies and production processes with low-impact GREEN raw materials.

Mobil Plastic looks to the future with healthy optimism, aware of its know-how and ready to face and impose itself on the reference markets throughout Europe



# 2024

Mobil Plastic guarda al futuro e l'azienda si prepara ad affrontare sfide ambiziose, come l'ulteriore riduzione delle emissioni nella filiera produttiva, l'integrazione di tecnologie ancora più avanzate per il riciclo, e l'espansione verso mercati internazionali sempre più sensibili alla sostenibilità ambientale.

Mobil Plastic raggiunge nuovi importanti traguardi ottenendo: La certificazione "Plastica Seconda Vita", che prevede l'utilizzo di materiali plastici riciclati certificati di consumo post-industriale, riducendo significativamente l'impatto ambientale e promuovendo in pieno un'economia circolare. La Certificazione "UNI EN ISO 9001:2015" per la gestione, progettazione e realizzazione di prodotti in materiale plastico e successiva commercializzazione.

*Mobil Plastic thinks forward and the company is preparing for ambitious challenges, like further emissions reductions in the production chain, introducing even more advanced technologies for recycling, and developing international markets where environmental sustainability is becoming more and more one of the major topics. Mobil Plastic achieving new important goals and obtaining: The "Plastic Second Life" certification, which refers to the use of certified recycled plastic materials coming from the post-industrial consumption, significantly reducing the environmental impact and fully promoting a circular economy. The "UNI EN ISO 9001:2015" Certification for the management, design and production of plastic products and their marketing.*

# Ambiente

## Mobil Plastic per l'Ambiente

Mobil Plastic è impegnata in prima linea investendo in risorse e tecnologie per sostenere una filiera produttiva e logistica volta a salvaguardare, tutelare e rispettare l'ambiente e il mondo che ci circonda. Largo utilizzo di materie prime provenienti da POST CONSUMO, riciclate e riciclabili al 100% rendono i prodotti Mobil Plastic a basso impatto ambientale e in linea con una concezione "GREEN" seguendo e applicando direttive delle principali organizzazioni mondiali sull'ambiente e più in generale su concetti di "Economia circolare". Anche gli approvvigionamenti da fornitori esterni sono controllati e scelti accuratamente in base al concetto di "KM 0" per diminuire al massimo il trasporto e l'inquinamento ambientale. Materiali di nuova applicazione per il settore dello stampaggio ad iniezione sono utilizzati da Mobil Plastic, come ad esempio il "PET" proveniente dalla filiera del riciclo bottiglie di plastica. Mobil Plastic garantisce per ogni singolo suo prodotto, la massima attenzione alla qualità, alla durata e alla produzione a basso impatto ambientale.

## Mobil Plastic for the Environment

Mobil Plastic is committed to the forefront by investing in resources and technologies to support a production and logistics chain aimed at safeguarding, protecting and respecting the environment and the world around us. Wide use of raw materials from POST-CONSUMPTION, recycled and 100% recyclable, make Mobil Plastic products with low environmental impact and in line with a "GREEN" concentration, following and applying directives from world organizations on the environment and more generally on concepts of "Circular Economy".

Even supplies from external suppliers are controlled and chosen on the basis of the "KM 0" concept to minimize transport and environmental pollution. Newly applied materials for the injection molding sector are used by Mobil Plastic, such as "PET" from the plastic bottle recycling chain. Mobil Plastic guarantees for each single product, the utmost attention to quality, duration and production with low environmental impact.

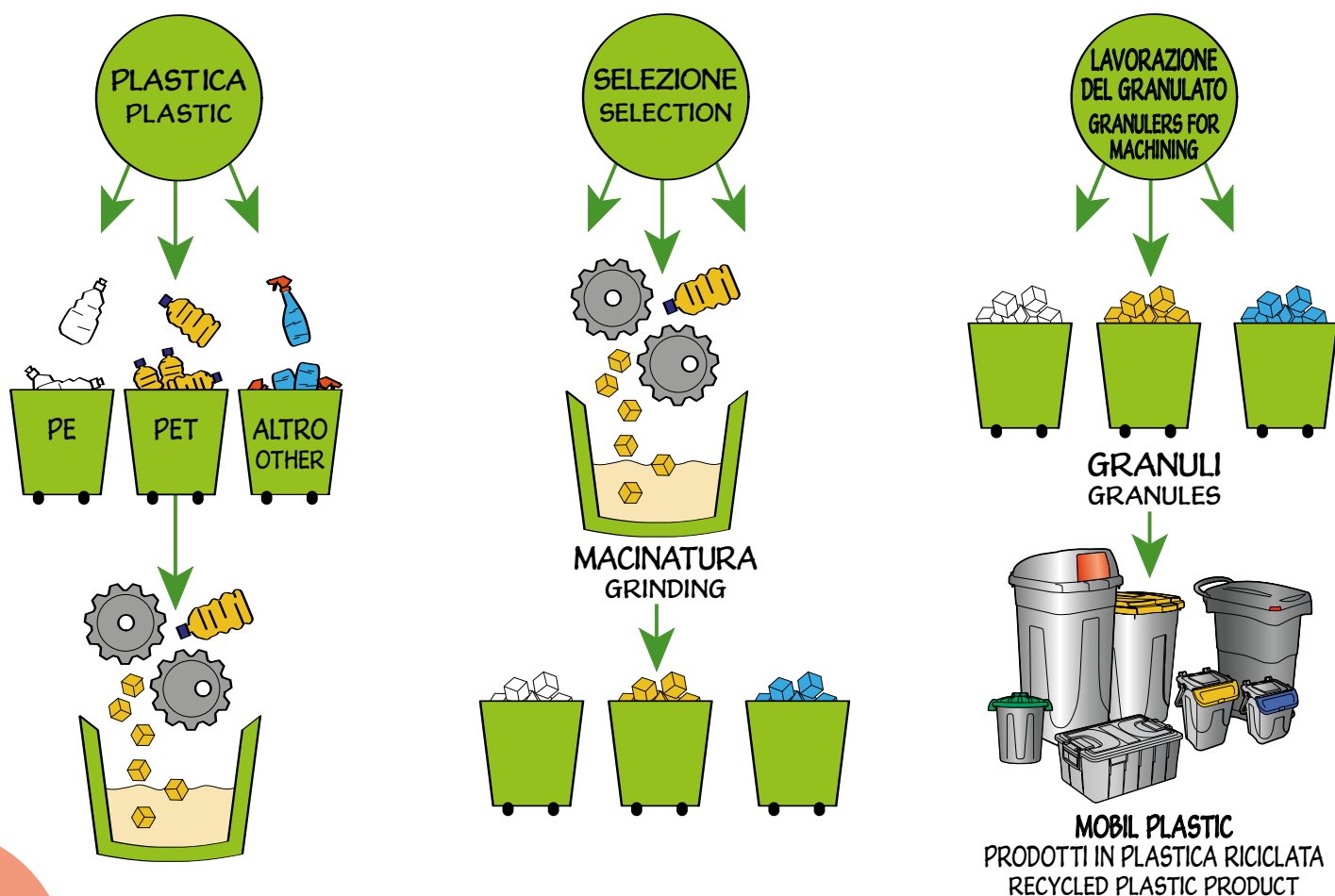

## Autonomia Energetica

Grazie ai nostri impianti fotovoltaici siamo in grado di generare autonomamente buona parte dell'energia necessaria alla nostra produzione, risparmiando così preziose risorse ambientali senza inquinare.

## Energy Independence

Thanks to our photovoltaic systems, we are able to generate electricity, thus saving environmental resources.



# FOTOVOLTAICO



superficie coperta da impianto fotovoltaico: **circa 5000 m<sup>2</sup>**

data di prima attivazione: **31/10/2011**

potenza di picco impianto: **964 kWp**

media annuale energia prodotta: **600.000 kWp**

media annuale equivalente a petrolio non utilizzato: **n.360 barili**

media annuale alberi salvati equivalenti: **2.800**

media annuale emissioni di anidride carbonica evitate: **360.000 kg**





# Ambiente

## Certificazione plastica seconda vita

Il marchio "PLASTICA SECONDA VITA" (PSV) viene assegnato dall'Istituto IPPR (Istituto Promozione Plastiche Riciclo) dopo attente analisi e procedure.

Si tratta di un sistema di certificazione ambientale dei prodotti ottenuti dal riciclo di rifiuti plastici domestici e post-industriali.

Tale certificazione PSV, la prima in ambito Europeo, esprime un concetto di qualità e rintracciabilità dei materiali impiegati, con riferimento al DM attuativo 203/2003 relativo al GREEN PUBLIC PROCUREMENT e alle normative di riferimento.

Mobil Plastic, anche attraverso il riconoscimento ottenuto di PSV, persegue l'obiettivo di produzione a BASSO IMPATTO AMBIENTALE utilizzando materie prime riciclate da prodotti già utilizzati e contribuendo ad alimentare il ciclo di ECONOMIA CIRCOLARE.

Tutti gli articoli a catalogo MOBIL PLASTIC contraddistinti dal simbolo PSV - plastica 2° vita sono realizzati con materiali idonei e conformi alla certificazione dell'istituto IPPR ed immessi sul mercato rispettando tutte le normative di riferimento in ambito comunitario e Italiano

## Certificate second life plastic

The "SECOND LIFE PLASTIC" (PSV) brand is assigned by the IPPR institute (the Italian institute for the promotion of plastic recycling) after a thorough check and procedures. It is an environmental certification system for products obtained from the recycling of domestic and post-industrial plastic waste.

This PSV certification, the first in Europe, expresses a concept of quality and traceability of the materials used, according to the implementing Ministerial Decree 203/2003 relating to green public procurement and the relevant regulations. Mobil Plastic, also through the certification obtained by PSV, pursues the goal of lowest environmental impact production using recycled raw materials from products that have already been used and helping to feed the circular economy cycle.

All the items in the MP catalogue marked with the "PSV - second life plastic" symbol are made with suitable materials and comply with the IPPR institute certification and placed on the market in compliance with all the relevant regulations in Italy and in the European Community.



plastica  
seconda vita  
MIX ECO

## Certificato n° 886/2023

Scopo <i>Scope</i>	<b>Manufatti ottenuti mediante stampaggio di materie plastiche di riciclo da raccolta differenziata o scarto industriale (MIXECO).</b> <i>Products obtained by molding recycled plastic materials from separate collection or industrial waste (MIXECO).</i>
Gamma di prodotti <i>Range of products</i>	<b>vedere allegato / see annex</b>
Nome commerciale <i>Trade name</i>	<b>vedere allegato / see annex</b>
Produttore <i>Manufacturer</i>	<b>MOBIL PLASTIC SPA</b>
Sede legale <i>Head office</i>	<b>VIA ROBBIO, 31 — 27030 CONFENZA (PV)</b>
Sito produttivo <i>Production site</i>	<b>VIA ROBBIO, 31 — 27030 CONFENZA (PV) VIA ENRICO MATTEI, 14 - 27038 ROBBIO (PV)</b>

IIP Srl certifica che i prodotti sopra elencati ottenuti dall'impiego di materiali da riciclo sono conformi ai requisiti specificati nel Regolamento di certificazione "Plastica Seconda Vita" Ed. 2 rev. 1 del 10/2022.

Il produttore, sottoposto a sorveglianza continua da parte di IIP Srl, è quindi autorizzato ad apporre sui prodotti certificati il marchio "Plastica Seconda Vita" PSV/MixEco con numero distintivo **5661** ed utilizzarlo in conformità alle prescrizioni del Regolamento per l'uso del marchio PSV Ed. 2 rev. 5 del 10/2022.

Il presente certificato di conformità è valido, salvo modifica, sospensione o revoca, fino al **07/02/2026**.

*IIP Srl certifies that the above listed products obtained from the use of recycled materials comply with the requirements specified in the "Rules for the PSV certification" ed. 2 rev. 1 issued 10/2022.*

*The Manufacturer, which is subjected to continuous surveillance by IIP Srl, is so entitled to put on the certified products the "Plastica Seconda Vita" PSV/MixEco mark with the distinctive number 5661 and to use it in compliance with the "Rules for the use of PSV mark" ed. 2 rev. 5 issued 10/2022.*

*This certificate of conformity is valid, unless modification, suspension or revocation, until 07/02/2026.*

Prima emissione **08/02/2023**  
*First issue*

Emissione corrente **08/02/2023**  
*Current issue*

Scadenza **07/02/2026**  
*Expiry*



Via Velleia, 2 - 20090 Monza (MB)  
Tel +39 039 2045700 - Fax +39 039 2045701  
[www.iip.it](http://www.iip.it) - [info@iip.it](mailto:info@iip.it)

ISTITUTO ITALIANO DEI PLASTICI SRL

L'Amministratore Delegato  
(Mauro La Ciacera)



PRD N° 006B

Membro degli Accordi di Mutuo  
Riconoscimento EA, IAFe ILAC

Plastica Seconda Vita è un marchio registrato di proprietà di IPPR - Istituto per la Promozione della Plastiche da Riciclo  
IPPR - Via San Vittore, 36 - 20123 Milano [www.iipr.it](http://www.iipr.it)

# Ambiente



## **Certificazione 100% GREEN**

Tutti gli articoli a catalogo Mobil Plastic contraddistinti da questo simbolo, sono realizzati con materie prime riciclabili o riciclate da post consumo.

## **Certificate 100% GREEN**

*All items on Mobil Plastic catalog, marked with this symbol, are made with recyclable or post-consumer recycled raw materials.*

## **Mobil Plastic è Corporate Golden Donor FAI**

Mobil Plastic è membro Corporate Golden Donor FAI, associazione conosciuta in tutto il mondo. Essere membro Corporate Golden Donor FAI è segno di eccellenza ed è un modo concreto per contribuire ad una causa importante che Mobil Plastic abbraccia da anni con entusiasmo.

## **Mobil Plastic is Corporate Golden Donor FAI**

*Mobil Plastic is a FAI Corporate Golden Donor, association known all over the world. To be a FAI Corporate Golden Donor is a sign of excellence and gives a concrete contribution to an important cause that Mobil Plastic has joined for years with enthusiasm.*



# FAI

CORPORATE  
GOLDEN  
DONOR

*Noi sosteniamo il FAI*

# Qualità

## CERTIFICATO - ISO 9001 - CERTIFIED

Mobil Plastic è orgogliosa di aver ottenuto la certificazione **UNI EN ISO 9001: 2015**, lo standard internazionale che attesta l'eccellenza del nostro sistema di gestione per la qualità.

Questo importante riconoscimento rappresenta il risultato di un impegno continuo nella ricerca dell'efficienza, della precisione e della soddisfazione del cliente.

La certificazione **ISO 9001** non è soltanto un simbolo di conformità ad elevati standard rigorosi, ma riflette la filosofia aziendale **Mobil Plastic**: il cliente al centro di ogni processo e la garanzia di realizzare ed erogare prodotti e servizi che rispondano pienamente alle sue aspettative, rispettando i più alti standard qualitativi. Per i nostri clienti, questa certificazione significa poter scegliere ed affidarsi a un partner affidabile, che opera con processi ottimizzati, monitorati e in costante miglioramento. È la dimostrazione tangibile del nostro impegno nel mantenere relazioni trasparenti e nell'offrire soluzioni che rappresentino il meglio del nostro settore.

*Mobil Plastic is proud to be **UNI EN ISO 9001: 2015** certified, the international standard that proves the excellence of our quality management system. This important achievement represents the result of a continuous commitment to efficiency, accuracy and customer satisfaction.*

*The **ISO 9001** certification is not only a sign of strictly high standards, but also it shows the **Mobil Plastic** corporate philosophy: the customers at the center of every process and the commitment to provide products and services fully meeting their expectations, always at the top quality standards.*

*For our customers, this certification means the possibility to choose and trust a reliable partner, operating with optimized, controlled processes in continuous improvement. This is the clear evidence of our loyalty to a transparent relationship and obligation to offer always the best solution of our market.*

	
<b>CERTIFICATO</b>	Reg. Numero 21379 - A Valido da 2024-05-07
	Primo rilascio 2024-05-07 Ultima modifica 2024-05-07
	Scadenza 2027-05-06 Settore IAF 14, 29
	Certificato del Sistema di Gestione per la Qualità <b>ISO 9001:2015</b>
Si dichiara che il Sistema di Gestione per la Qualità dell'Organizzazione: <b>MOBIL PLASTIC S.p.A.</b>	
è conforme alla norma UNI EN ISO 9001:2015 per i seguenti prodotti/servizi: Progettazione e realizzazione attraverso processi di iniezione e soffiaggio di articoli in materiale plastico e commercializzazione di articoli in materiale plastico.	
Direttore Divisione Certificazione Sistemi di Gestione Giovanni Balducci 	
Il mantenimento della certificazione è soggetto a sorveglianza annuale e subordinato al rispetto dei requisiti contrattuali di Kiwa Cermet Italia.	
Questo certificato è costituito da 1 pag.	
<b>MOBIL PLASTIC S.p.A.</b> Sede Legale Via Robbio, 31 27030 Confindenza (PV) Italia Sedi oggetto di certificazione Via Robbio, 31 27030 Confindenza (PV) Italia	
 Kiwa Cermet Italia S.p.A. Società con socio unico, soggetta all'attività di direzione e coordinamento di Kiwa Italia Holding Srl Via Cadriano, 23 40057 Granarolo dell'Emilia (BO) Tel +39 051 459 3 111 Fax +39 051 763 382 E-mail: info@kiwacermet.it www.kiwa.it	  MS N° 000795



14



**Serie 2000**

16



**Serie C500**

18



**Serie KOMBI**

24



**SERIE EUROPA**  
400x300 600x400

27



**Casse MULTIUSO**

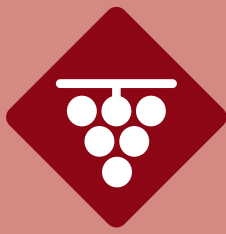

# FERRAMENTA & MAGAZZINO

## Hardware & Storage

28



**CRYSTAL BOX**

46



**MINI**

48



**MIDI**

50



**MAXI**

58



**CLASS**

64



**ESPACE**

# Serie 2000

contenitori sovrappponibili

## FERRAMENTA & MAGAZZINO

Hardware & Storage



art	L	H	P	Capacità Capacity	Imballo pezzi Pack quantity
2001	103	55	90	0,4 l	100
2001/B	103	62	120	0,7 l	100
2002	103	83	165	1 l	48
2002/L	103	83	240	2 l	28
2003	145	125	240	3,5 l	38
2003/L	145	125	335	6 l	16
2004	207	165	345	10 l	20
2005	303	190	485	30 l	12
2005/S	363	250	580	52 l	4

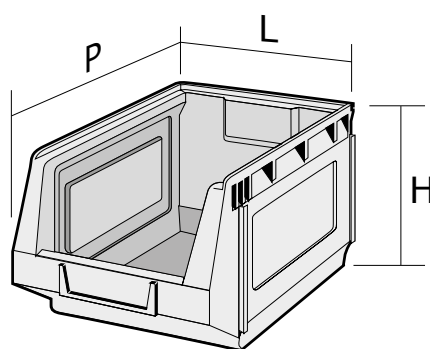

## Coperchio SERIE 2000



Coperchio  
trasparente per  
**2001**



Coperchio  
trasparente per  
**2001/B**



Coperchio  
trasparente per  
**2002**



PRODOTTI IN  
MATERIALE  
RICICLABILE



2001



2001/B



2002



2002/L



2003



2003/L



2004



2005



2005/S



PRODOTTI IN  
MATERIALE  
RICICLABILE



# Serie C500

contenitori sovrapponibili e componibili

## FERRAMENTA & MAGAZZINO

Hardware & Storage

art	L	H	P	Capacità Capacity	Imballo pezzi Pack quantity
C 502	105	85	163	1 l	48
C 503	150	125	240	3,5 l	38
C 504	212	165	345	10 l	24
C 505	305	190	485	30 l	12
C 505/S	370	250	580	52 l	4

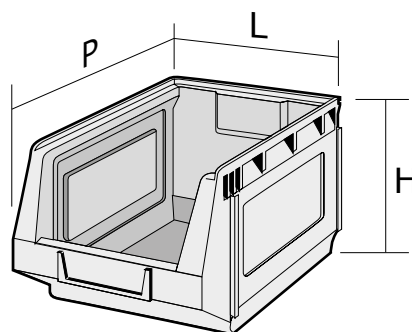



### Componibili ad incastro laterale

*Side interlocking system*

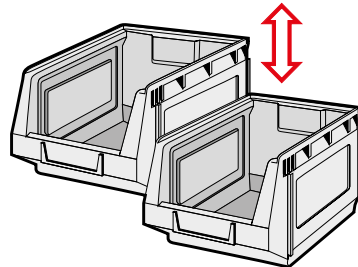

C 502



C 503



C 504



C 505



C 505/S



PRODOTTI IN  
MATERIALE  
RICICLABILE

# Serie KOMBI

contenitori sovrapponibili e componibili

## FERRAMENTA & MAGAZZINO

Hardware & Storage

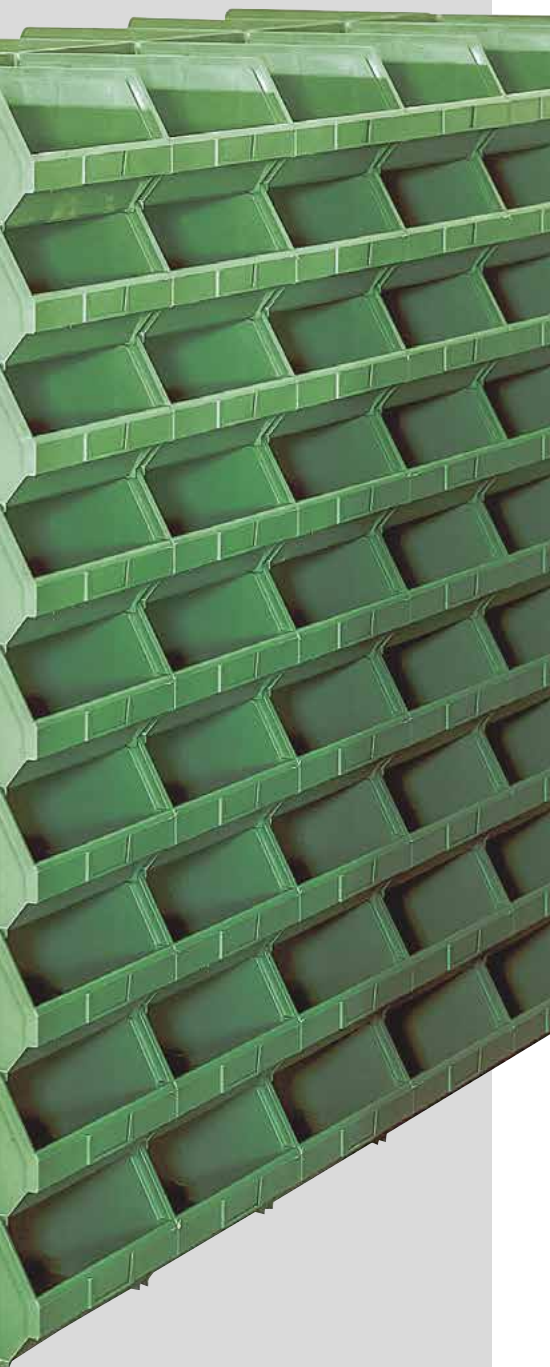

art	L	H	P	Capacità Capacity	Imballo pezzi Pack quantity
1 PST	103	53	95	0,4 l	100
2 K	108	75	167	1 l	48
3 K	151	128	240	3,5 l	38
3 KB	296	128	240	7 l	24
3 KBD	296	128	240	7 l	24
4 K	213	165	350	10 l	24
5 K	310	190	490	30 l	12
5 KD	310	190	490	30 l	12
5 KS	385	250	580	52 l	4
5 KSD	385	250	580	52 l	4
6 K	450	300	710	95 l	4
6 KD	450	300	710	95 l	4

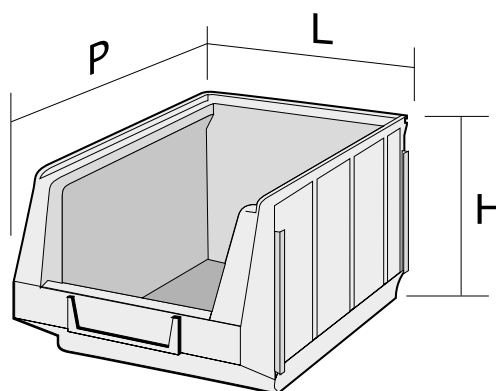

### Componibili ad incastro laterale e posteriore

*Back and side interlocking system*

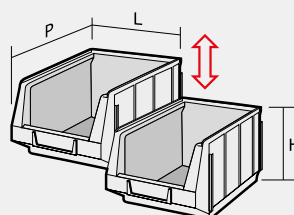

2 K - 3 K - 3 KB - 3 KBD - 4 K - 5 K  
5 KD 5 KS - 5 KSD - 6 K - 6 KD

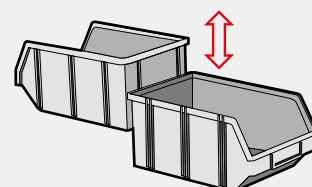

3 KB - 3 KBD - 4 K - 5 K - 5 KD  
5 KS - 5 KSD - 6 K - 6 KD



1 PST



2 K



3 K



3 KB



3 KBD



4 K



5 K



5 KD



5 KS



5 KSD



6 K



6 KD



PATELETTA 4 K - 5 K



PRODOTTI IN  
MATERIALE  
RICICLABILE



# PENSIL

## pannelli pensili serie 2000

### FERRAMENTA & MAGAZZINO

Hardware & Storage

Pannelli flangiati portacontenitori in robusta lamiera stampata, verniciati a forno in polvere epossidica di colore rosso.

*Flanged panel for bins constructed of sheet steel, epoxy powder coating.*

art	L	H	P	Imballo Pezzi Pack quantity
MP 90	1.000	455	15	2
MP 45	495	455	15	2

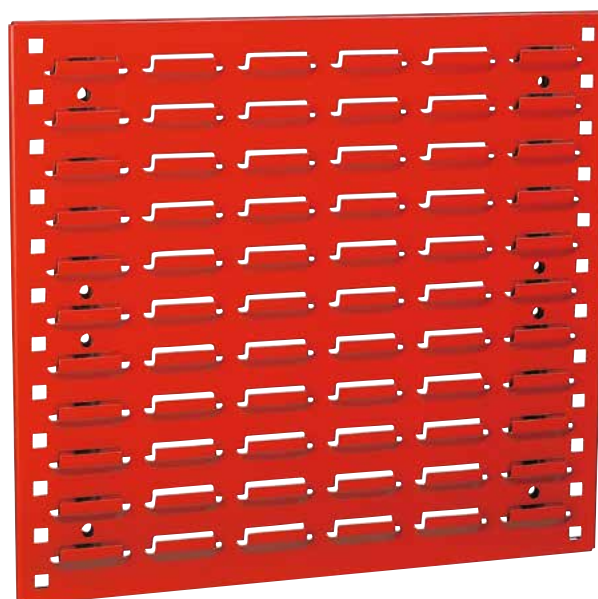
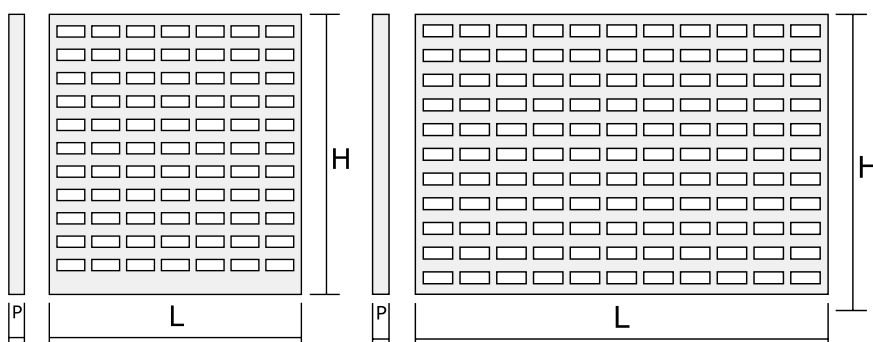

**MP 45**

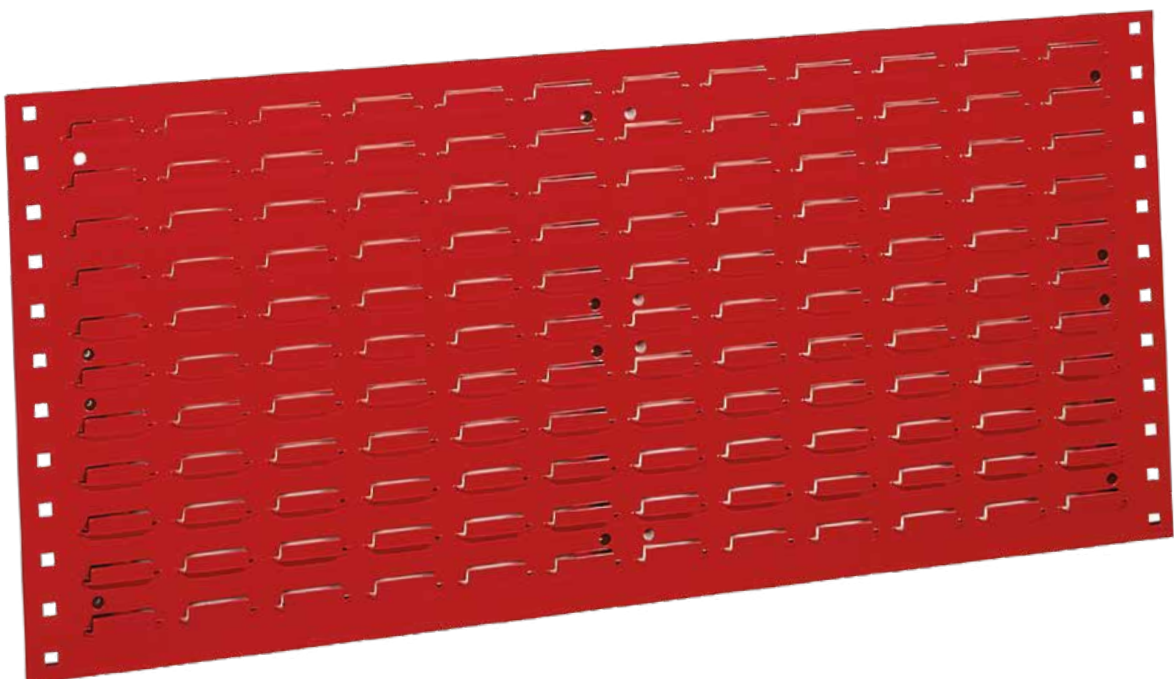

**MP 90**



PRODOTTI IN  
MATERIALE  
RICICLABILE

# CARRELLI

## portacontenitori serie 2000

### FERRAMENTA & MAGAZZINO

Hardware & Storage



Robusti e pratici carrelli per esigenze di magazzino mobile. Realizzati in lamiera elettrosaldata e verniciati a forno in polvere epossidica di colore rosso. Dotati di n. 4 ruote gomminate di cui 2 piroettanti (una con fermo). Forniti smontati con schema e minuterie per l'assemblaggio.

*Strong and practical trolleys for mobile storage. Made of electro-welded plate and oven painted with red epoxy powder. Equipped with nr. 4 gummed wheels, 2 of them are pirouetting (1 with brake). Supplied disassembled with a handbook, screw and bolts for assembly.*

art	L	H	P	Imballo Pezzi Pack quantity
MP 30/C	610	1.300	610	1
MP 60	1.060	1.300	610	1

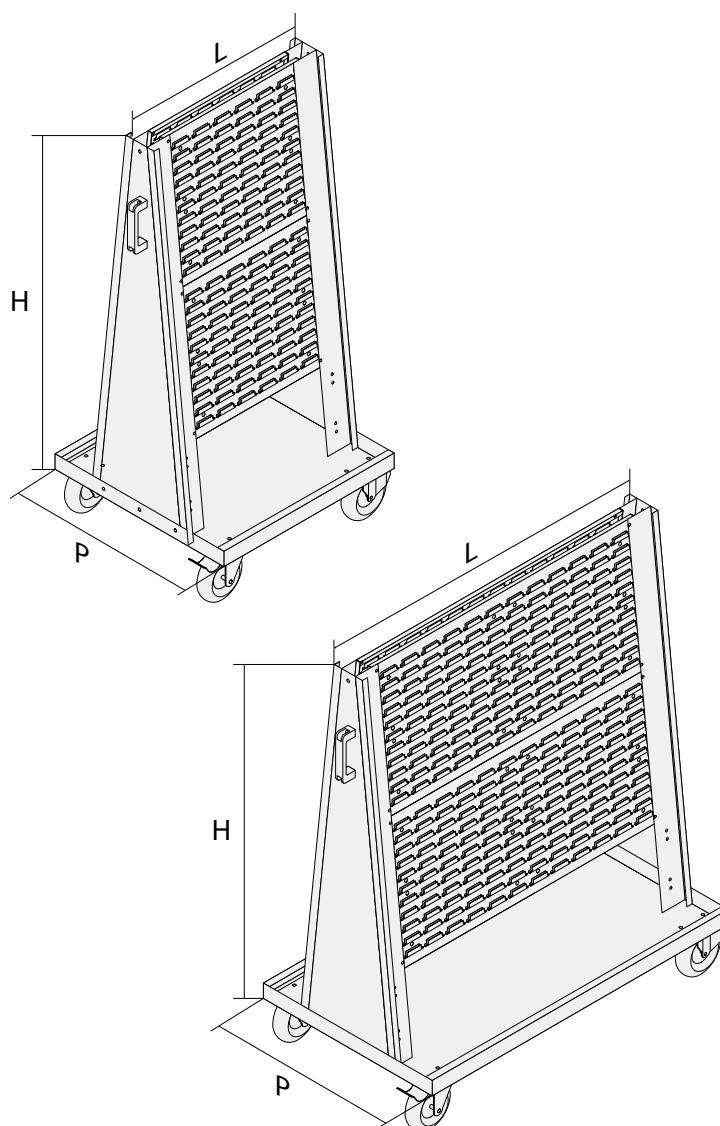

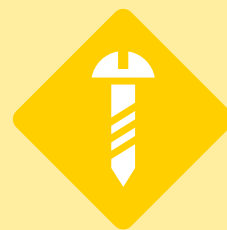

## \* KIT CONTENITORI SERIE 2000

### KIT MP 30/C

Totale numero contenitori: 60

Total number of bins: 60

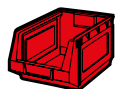

2003= n.12



2002= n.32



2001= n.16

### KIT MP 60

Totale numero contenitori: 120

Total number of bins: 120

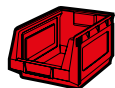

2003= n.24



2002= n.64



2001= n.32

\* Ordinabili separatamente

\* To be order separately



### MP 60

(prodotto privo di contenitori)  
(item supplied without bins)



### MP 30/C

(prodotto privo di contenitori)  
(item supplied without bins)



PRODOTTI IN  
MATERIALE  
RICICLABILE



# SERIE EUROPA

## 400x300

### FERRAMENTA & MAGAZZINO

Hardware & Storage

art.	L	P	H
2210-GRI	400	300	10
2213-GRI	400	300	13
2217-GRI	400	300	17
2222-GRI	400	300	22
2232-GRI	400	300	32
2200-GRI	400	300	—
2200C-GRI	400	300	—

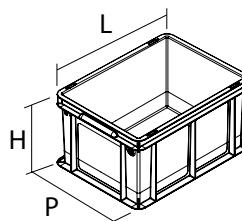

impilabili



SERIE EUROPA 400x300  
MANIGLIE INTEGRATE  
*EURONORM CRATE 400X300  
INTEGRATED HANDLES*



SERIE EUROPA 400X300  
PREDISPOSTA PER CHIUSURA E  
SIGILLO GARANZIA  
*EURONORM 400X300 CRATE  
DESIGNED FOR CLOSURE AND  
GUARANTEE SEAL*



SERIE EUROPA 400X300  
PREDISPOSTA PER CHIUSURA  
*EURONORM CRATE 400X300  
DESIGNED FOR LOCKING*

●  
GRIGIO (GRI)



**plastica**  
seconda vita  
MIX ECO



**2210-GRI**



**2213-GRI**



**2217-GRI**



**2222-GRI**



**2232-GRI**



**2200-GRI**

**COPERCHIO PER CASSA 400X300**  
*LID FOR 400x300 CRATE*



**2200C-GRI**

**COPERCHIO PER CASSA 400X300**  
**CON CHIUSURA**  
*LID FOR 400x300 CRATE WITH*  
*LOCKING*



PRODOTTI IN  
MATERIALE  
RICICLABILE

# SERIE EUROPA

600x400

## FERRAMENTA & MAGAZZINO

Hardware & Storage



art.	L	P	H
4407-GRI	600	400	7
4410-GRI	600	400	10
4413-GRI	600	400	13
4417-GRI	600	400	17
4422-GRI	600	400	22
4432-GRI	600	400	32
4400-GRI	600	400	—

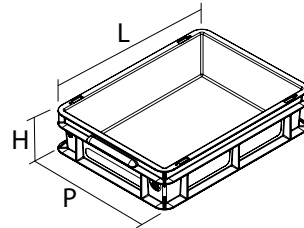

impilabili

**plastica**  
seconda vita  
MIX ECO



**4400-GRI**  
COPERCHIO PER SERIE 600X400  
LID FOR 600x400 CRATE



**4407-GRI**



**4410-GRI**



**4413-GRI**



**4417-GRI**



**4422-GRI**



**4432-GRI**

GRIGIO (GRI)



PRODOTTI IN  
MATERIALE  
RICICLABILE

# CASSE MULTIUSO CON COPERCHIO

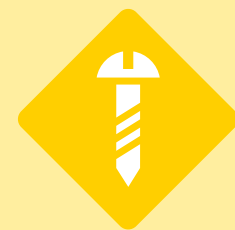

art.	L	H	P	Capacità Capacity
143/20-GRI	38	30	28	20 l
143/40-GRI	58	26	38	40 l
143/60-GRI	58	38	38	60 l

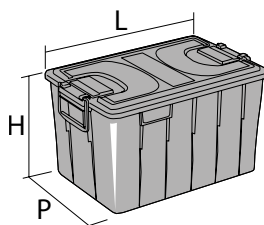

Porta targhetta  
Tag holder

**plastica**  
seconda vita  
MIX ECO

Casse grandi e piccole tra loro  
sovrapponibili per facilitarne il trasporto,  
coperchio in dotazione con chiusura

*Large and small crates can be put one  
on the other to facilitate transport,  
supplied lid with closure*



**143/20-GRI**



**143/40-GRI**



**143/60-GRI**

●  
GRIGIO (GRI)



PRODOTTI IN  
MATERIALE  
RICICLABILE

# CRYSTAL BOX

cassettiere

**FERRAMENTA  
& MAGAZZINO**  
Hardware & Storage

## CASSETTI

Realizzati in PET (Polietilene tereftalato), infrangibili, proprietà antistatiche, resistenti ad agenti chimici aggressivi e ad oli e acidi, elevata resistenza agli urti e al peso, assoluta trasparenza immutata nel tempo.

Utilizzabile da -50° a +150°

## DRAWERS

Made of PET (polyethylene terephthalate), shatterproof, with antistatic properties, resistant to aggressive chemical agents, oils and acids, shockproof and high weight resistance, total drawer transparency unchanged over time.

Working temperatures from -50° to +150°.

## STRUTTURA ESTERNA

Realizzata in Compound di Polipropilene con elevate caratteristiche di resistenza al carico. Totale assenza di spigoli e sensazione "soft touch" al tatto.

## CASE

High load resistance thanks to Polypropylene compound.

No edges and soft touch surface.



Connettore posteriore (solo per CB 50/3) ed etichette adesive in dotazione standard.  
Rear connector (only for CB 50/3) and standard labels included.



Fermo per Crystal Box.  
Locking bar for Crystal Box.



●  
GS  
(SIMIL RAL 7016)



●  
GC  
(SIMIL RAL 7035)



●  
BL  
(SIMIL RAL 5017)



Art.	DESCRIZIONE DESCRIPTION	L x P x H
CB 50/2S	Crystal Box - 5 cassetti <i>Crystal Box - 5 drawers</i>	STRUTTURA ESTERNA - CASE: 600 x 133 x 132 CASSETTO - DRAWER: 90 x 86 x 62
CB 50/3	Crystal Box - 1 cassetto <i>Crystal Box - 1 drawer</i>	STRUTTURA ESTERNA - CASE: 300 x 155 x 175 CASSETTO - DRAWER: 255 X 107 X 105
CB 50/3S	Crystal Box - 3 cassetti <i>Crystal Box - 3 drawers</i>	STRUTTURA ESTERNA - CASE: 600 x 155 x 175 CASSETTO - DRAWER: 160 X 107 X 105
CB 50/4S	Crystal Box - 3 cassetti <i>Crystal Box - 3 drawers</i>	STRUTTURA ESTERNA - CASE: 600 x 200 x 215 CASSETTO - DRAWER: 165 X 140 X 105
CB 50/5S	Crystal Box - 2 cassetti <i>Crystal Box - 2 drawers</i>	STRUTTURA ESTERNA - CASE: 600 x 240 x 300 CASSETTO - DRAWER: 258 X 190 X 165

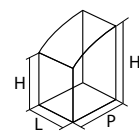
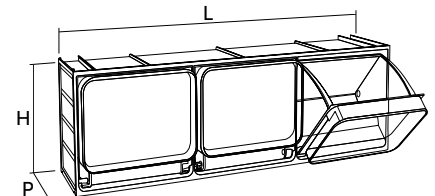

art	L	H	P
VASCB50/2S.TR Vaschetta per CB50/2S	48	60/95	88
VASCB50/3S.TR Vaschetta per CB50/3S	77	102/140	105

Ogni cassetto CB50/2S  
o CB50/3S può contenere  
2 vaschette estraibili.

Each drawer CB50/2S  
o CB50/3S can contain  
2 removable cups.

# CRYSTAL BOX

telai

## FERRAMENTA & MAGAZZINO

Hardware & Storage

### MP 100

Pratico telaio da banco o da parete. Realizzato in lamiera elettrosaldata e verniciato a forno in polvere epossidica.

### MP 100

*Practical frame for bench or wall. Made of epoxy powder coated electro-welded sheet.*

### MP 125

Robusto telaio per fissaggio a parete. Realizzato in lamiera elettrosaldata e verniciato a forno in polvere epossidica.

### MP 125

*Strong wall mounted frame. Made of epoxy powder coated electro-welded sheet.*

### MP 195 - MP 175 - MP 150

Pratici e robusti telai espositori con base.

Realizzati in lamiera elettrosaldata e verniciati a forno in polvere epossidica.

Forniti smontati con viteria per assemblaggio.

### MP 195 - MP 175 - MP 150

*Practical and strong frame with base.*

*Made of epoxy powder coated electro-welded sheet.*

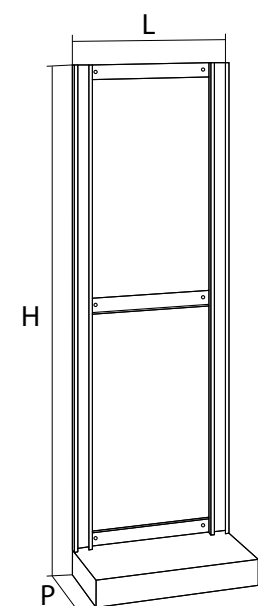
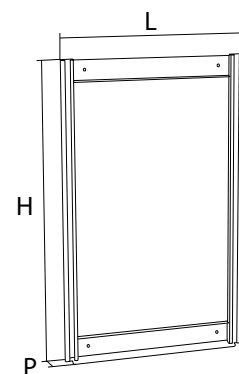
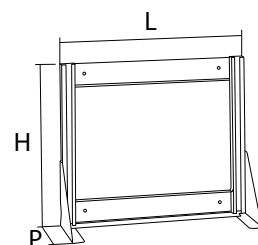

Esempio di allestimento

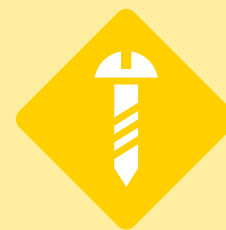

Art.	DESCRIZIONE DESCRIPTION	L x P x H
MP 100	espositore da banco per Crystal Box. <i>shelf display for Crystal Box.</i>	610 x 150 x 500
MP 125	espositore pensile per Crystal Box. <i>wall mounted frame for Crystal Box.</i>	605 x 40 x 1.000
MP 150	espositore con base per Crystal Box. <i>frame with base for Crystal Box.</i>	605 x 250 x 1.500 UTILE 1.400
MP 175	espositore con base per Crystal Box. <i>frame with base for Crystal Box.</i>	605 x 250 x 1.750 UTILE 1.650
MP 195	espositore con base per Crystal Box. <i>frame with base for Crystal Box.</i>	605 x 250 x 1.950 UTILE 1.850



MP 195



MP 175



MP 150



MP 100

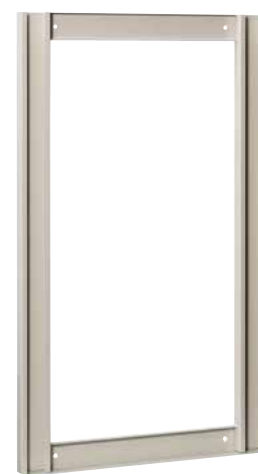

MP 125

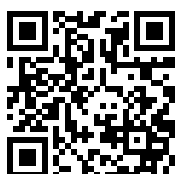

Esempio di incastro cassettiere Crystal Box su telaio espositore.  
*Instructions to set up a frame with Crystal Box.*



# CRYSTAL BOX

scaffali

## FERRAMENTA & MAGAZZINO

Hardware & Storage



### Robusto scaffale in lamiera elettrosaldata.

Consente l'allineamento frontale delle cassettiere Crystal Box.  
Verniciato a forno in polvere epossidica RAL 7035.  
Fornito già montato.

### Strong frame made of electro-welded plate.

All Crystal Box drawers are frontally aligned.  
Oven painted with epoxy powder RAL 7035.  
Supplied assembled.



Ogni cassetto CB50/2S o CB50/3S  
può contenere 2 vaschette estraibili.

Each drawer CB50/2S o CB50/3S  
can contain 2 removable cups.

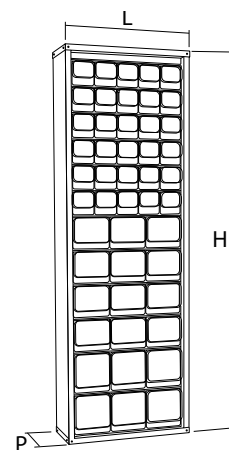

Esempio



Ral 7035  
(STRUTTURA - FRAME)

GS • (SIMIL RAL 7016)  
(CASSETTI - DRAWERS)



GC • (SIMIL RAL 7035)  
(CASSETTI - DRAWERS)



BL • (SIMIL RAL 5017)  
(CASSETTI - DRAWERS)

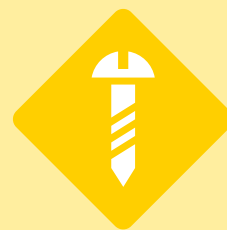

Art.	DESCRIZIONE DESCRIPTION	L x P x H
CB 200	scaffale con 30 cassetti. (4 CB50/4S + 6 CB50/3S) shelf with 30 drawers. (4 CB50/4S + 6 CB50/3S)	665 x 250 x 2.000
CB 200A	scaffale con 48 cassetti. (2 CB50/4S + 4 CB50/3S + 6 CB50/2S) shelf with 48 drawers. (2 CB50/4S + 4 CB50/3S + 6 CB50/2S)	665 x 250 x 2.000
CB 200D	scaffale con 60 cassetti. (8 CB50/4S + 12 CB50/3S) shelf with 60 drawers. (8 CB50/4S + 12 CB50/3S)	1.260 x 250 x 2.000
CB 200DA	scaffale con 96 cassetti. (4 CB50/4S + 8 CB50/3S + 12 CB50/2S) shelf with 96 drawers. (4 CB50/4S + 8 CB50/3S + 12 CB50/2S)	1.260 x 250 x 2.000



**CB 200A**



**CB 200D**

# CRYSTAL BOX

armadi CB 400/1

**FERRAMENTA  
& MAGAZZINO**  
Hardware & Storage



## Armadio a pannelli scorrevoli su cuscinetti a sfera.

Struttura con n. 2 pannelli fissi affiancati sul fondo + n. 1 scorrevole, realizzata in lamiera elettrosaldada con barre di rinforzo. Verniciata a forno con polvere epossidica. Fornito smontato con manuale di assemblaggio e viteria.

Portata singolo pannello: kg 160 circa.

Ruote e perni silenziati in nylon.

## Cabinet with sliding panels on balls bearing.

Frame equipped with n. 2 fixed panels placed side by side on the bottom + n. 1 sliding panel, made of electrowelded reinforced plate. Made of epoxy powder coated electro-welded sheet.

Supplied disassembled with a handbook for assembly and screw and bolts.

Load capacity of each panel: 160 kg about.

Silent running nylon rollers and pins.

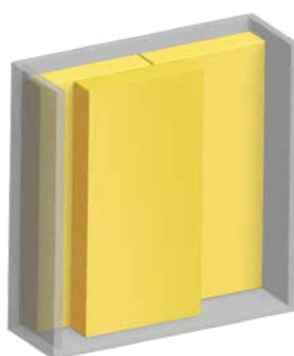

- Pannello fisso con n. 10 CB50/3S + n. 10 CB50/3S.  
Fixed panel with n. 10 CB50/3S + n. 10 CB50/3S.
- Pannello scorrevole con n. 10 CB50/3S.  
Sliding panel with n. 10 CB50/3S.

**Due pannelli fissi  
Un pannello scorrevole**  
Two fixed panels  
One sliding panel

**CB 400/1**

(90 cassetti - drawers)

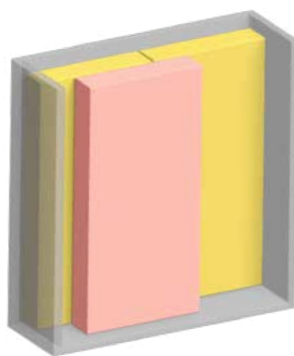

- Pannello fisso con n. 10 CB50/3S + n. 10 CB50/3S.  
Fixed panel with n. 10 CB50/3S + n. 10 CB50/3S.
- Pannello scorrevole con n. 14 CB50/2S.  
Sliding panel with n. 14 CB50/2S.

**Due pannelli fissi  
Un pannello scorrevole**  
Two fixed panels  
One sliding panel

**CB 400/1A**

(130 cassetti - drawers)

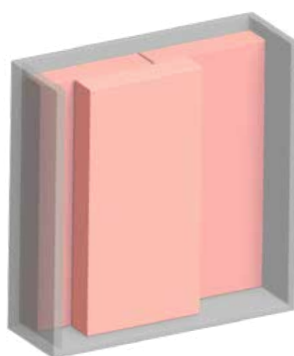

- Pannello fisso con n. 14 CB50/2S + n. 14 CB50/2S.  
Fixed panel with n. 14 CB50/2S + n. 14 CB50/2S.
- Pannello scorrevole con n. 14 CB50/2S.  
Sliding panel with n. 14 CB50/2S.

**Due pannelli fissi  
Un pannello scorrevole**  
Two fixed panels  
One sliding panel

**CB 400/1B**

(210 cassetti - drawers)

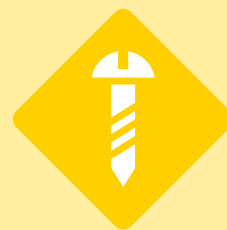

Art.	2 PANNELLI FISSI 2 FIXED PANELS	1 PANNELLO SCORREVOLE 1 SLIDING PANEL	TOT. CASSETTI TOTAL DRAWERS	L x P x H
CB 400/1	10 CB50/3S + 10 CB50/3S	10 CB50/3S	90	1.270 x 400 x 1.950
CB 400/1A	10 CB50/3S + 10 CB50/3S	14 CB50/2S	130	1.270 x 400 x 1.950
CB 400/1B	14 CB50/2S + 14 CB50/2S	14 CB50/2S	210	1.270 x 400 x 1.950



Luce LED per armadio  
LED light for cabinet



Ogni cassetto CB50/2S o CB50/3S  
può contenere 2 vaschette estraibili.  
Each drawer CB50/2S o CB50/3S  
can contain 2 removable cups.

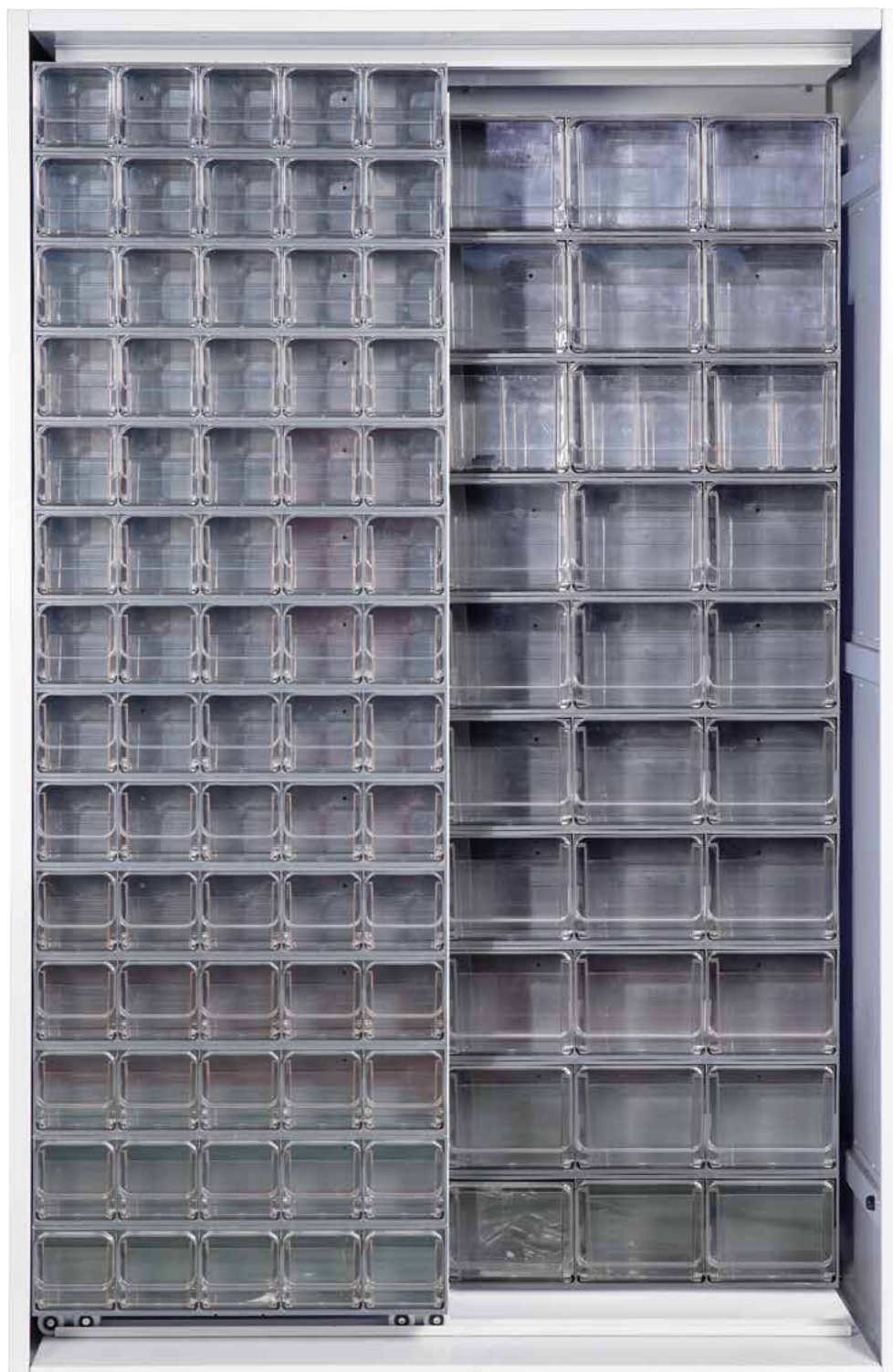

Esempio  
CB 400/1A



# CRYSTAL BOX

armadi CB 400/2

FERRAMENTA  
& MAGAZZINO  
Hardware & Storage



## Armadio a pannelli scorrevoli su cuscinetti a sfera.

Struttura con n. 2 pannelli fissi affiancati sul fondo + n. 2 scorrevoli, realizzata in lamiera elettrosaldada con barre di rinforzo. Verniciata a forno con polvere epossidica. Fornito smontato con manuale di assemblaggio e viteria.

Portata singolo pannello: kg 160 circa.

Ruote e perni silenziati in nylon.

## Cabinet with sliding panels on balls bearing.

Frame equipped with n. 2 fixed panels placed side by side on the bottom + n. 2 sliding panels, made of electrowelded reinforced plate. Made of epoxy powder coated electro-welded sheet.

Supplied disassembled with a handbook for assembly and screw and bolts.

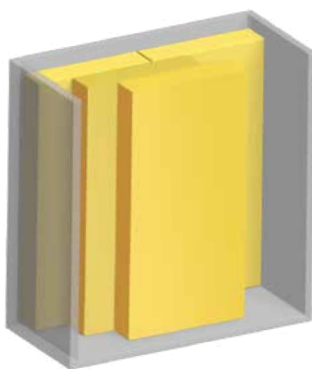

Load capacity of each panel: 160 kg about.

Silent running nylon rollers and pins.



CB 400/2

(120 cassetti - drawers)

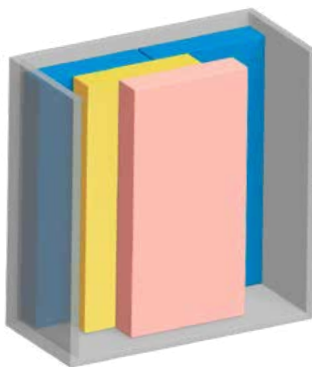

-  Pannello fisso con n. 10 CB50/3S + n. 10 CB50/3S.  
Fixed panel with n. 10 CB50/3S + n. 10 CB50/3S.
-  Pannello scorrevole con n. 10 CB50/3S.  
Sliding panel with n. 10 CB50/3S.
-  Pannello scorrevole con n. 10 CB50/3S.  
Sliding panel with n. 10 CB50/3S.

**Due pannelli fissi  
Due pannelli scorrevoli**  
Two fixed panels  
Two sliding panels



CB 400/2A

(154 cassetti - drawers)

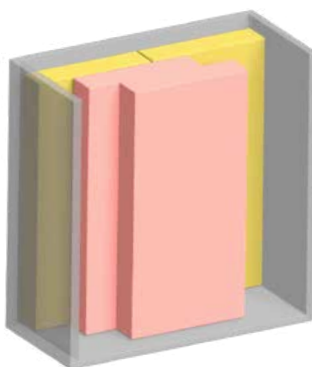

-  Pannello fisso con n. 10 CB50/4S + n. 8 CB50/3S.  
Fixed panel with n. 10 CB50/4S + n. 8 CB50/3S.
-  Pannello scorrevole con n. 10 CB50/3S.  
Sliding panel with n. 10 CB50/3S.
-  Pannello scorrevole con n. 14 CB50/2S.  
Sliding panel with n. 14 CB50/2S.

**Due pannelli fissi  
Due pannelli scorrevoli**  
Two fixed panels  
Two sliding panels



CB 400/2B

(200 cassetti - drawers)

-  Pannello fisso con n. 10 CB50/3S + n. 10 CB50/3S.  
Fixed panel with n. 10 CB50/3S + n. 10 CB50/3S.
-  Pannello scorrevole con n. 14 CB50/2S.  
Sliding panel with n. 14 CB50/2S.
-  Pannello scorrevole con n. 14 CB50/2S.  
Sliding panel with n. 14 CB50/2S.

**Due pannelli fissi  
Due pannelli scorrevoli**  
Two fixed panels  
Two sliding panels

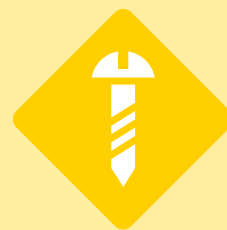

Art.	2 PANNELLI FISSI 2 FIXED PANELS	1 PANNELLO SCORR. POST. 1 REAR SLIDING PANELS	1 PANNELLO SCORR. ANT. 1 SLIDING FRONT PANEL	TOT. CASSETTI TOTAL DRAWERS	L x P x H
CB 400/2	10 CB50/3S + 10 CB50/3S	10 CB50/3S	10 CB50/3S	120	1.270 x 600 x 1.950
CB 400/2A	10 CB50/4S + 8 CB50/3S	10 CB50/3S	14 CB50/2S	154	1.270 x 600 x 1.950
CB 400/2B	10 CB50/3S + 10 CB50/3S	14 CB50/2S	14 CB50/2S	200	1.270 x 600 x 1.950



Luce LED per armadio  
LED light for cabinet



Ogni cassetto CB50/2S o CB50/3S  
può contenere 2 vaschette estraibili.  
Each drawer CB50/2S o CB50/3S  
can contain 2 removable cups.



Esempio  
CB 400/2A

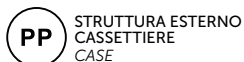

# CRYSTAL BOX

armadi CB 400/3

**FERRAMENTA  
& MAGAZZINO**  
Hardware & Storage



## Armadio a pannelli scorrevoli su cuscinetti a sfera.

Struttura con n. 2 pannelli fissi affiancati sul fondo + n. 3 scorrevoli, realizzata in lamiera elettrosaldata con barre di rinforzo. Verniciata a forno con polvere epossidica.

Fornito smontato con manuale di assemblaggio e viteria.

Portata singolo pannello: kg 160 circa.

Ruote e perni silenziati in nylon.

## Cabinet with sliding panels on balls bearing.

Frame equipped with n. 2 fixed panels placed side by side on the bottom + n. 3 sliding panels, made of electrowelded reinforced plate. Made of epoxy powder coated electro-welded sheet.

Supplied disassembled with a handbook for assembly and screw and bolts.

Load capacity of each panel: 160 kg about.

Silent running nylon rollers and pins.



**CB 400/3**  
(144 cassetti - drawers)

**Pannello fisso con n. 10 CB50/4S + n. 8 CB50/3S.**  
*Fixed panel with n. 10 CB50/4S + n. 8 CB50/3S.*

**Pannello scorrevole post. con n. 10 CB50/3S.**  
*Sliding panel with n. 10 CB50/3S.*

**Pannello scorrevole mediano con n. 10 CB50/3S.**  
*Sliding panel with n. 10 CB50/3S.*

**Pannello scorrevole ant. con n. 10 CB50/3S.**  
*Sliding panel with n. 10 CB50/3S.*

**Due pannelli fissi  
Tre pannelli scorrevoli**

**Two fixed panels  
Three sliding panels**



**CB 400/3A**  
(150 cassetti - drawers)

**Pannello fisso con n. 10 CB50/3S + n. 10 CB50/3S.**  
*Fixed panel with n. 10 CB50/3S + n. 10 CB50/3S.*

**Pannello scorrevole post. con n. 10 CB50/3S.**  
*Sliding panel with n. 10 CB50/3S.*

**Pannello scorrevole mediano con n. 10 CB50/3S.**  
*Sliding panel with n. 10 CB50/3S.*

**Pannello scorrevole ant. con n. 10 CB50/3S.**  
*Sliding panel with n. 10 CB50/3S.*

**Due pannelli fissi  
Tre pannelli scorrevoli**

**Two fixed panels  
Three sliding panels**



**CB 400/3B**  
(224 cassetti - drawers)

**Pannello fisso con n. 10 CB50/4S + n. 8 CB50/3S.**  
*Fixed panel with n. 10 CB50/4S + n. 8 CB50/3S.*

**Pannello scorrevole post. con n. 10 CB50/3S.**  
*Sliding panel with n. 10 CB50/3S.*

**Pannello scorrevole mediano con n. 14 CB50/2S.**  
*Sliding panel with n. 14 CB50/2S.*

**Pannello scorrevole ant. con n. 14 CB50/2S.**  
*Sliding panel with n. 14 CB50/2S.*

**Due pannelli fissi  
Tre pannelli scorrevoli**

**Two fixed panels  
Three sliding panels**

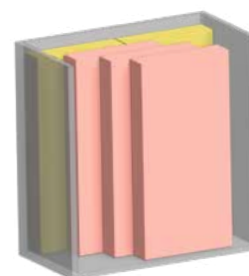

**CB 400/3C**  
(270 cassetti - drawers)

**Pannello fisso con n. 10 CB50/3S + n. 10 CB50/3S.**  
*Fixed panel with n. 10 CB50/3S + n. 10 CB50/3S.*

**Pannello scorrevole post. con n. 14 CB50/2S.**  
*Sliding panel with n. 14 CB50/2S.*

**Pannello scorrevole mediano con n. 14 CB50/2S.**  
*Sliding panel with n. 14 CB50/2S.*

**Pannello scorrevole ant. con n. 14 CB50/2S.**  
*Sliding panel with n. 14 CB50/2S.*

**Due pannelli fissi  
Tre pannelli scorrevoli**

**Two fixed panels  
Three sliding panels**



Art.	2 PANNELLI FISSI 2 FIXED PANELS	1 PANN. SCORR. POST. 1 REAR SLIDING PANELS	1 PANN. SCORR. MEDIANO 1 REAR SLIDING PANELS	1 PANN. SCORR. ANT. 1 SLIDING FRONT PANEL	TOT. CASSETTI TOT. DRAWERS	L x P x H
CB 400/3	10 CB50/4S + 8 CB50/3S	10 CB50/3S	10 CB50/3S	10 CB50/3S	144	1.270 x 800 x 1.950
CB 400/3A	10 CB50/3S + 10 CB50/3S	10 CB50/3S	10 CB50/3S	10 CB50/3S	150	1.270 x 800 x 1.950
CB 400/3B	10 CB50/4S + 8 CB50/3S	10 CB50/3S	14 CB50/2S	14 CB50/2S	224	1.270 x 800 x 1.950
CB 400/3C	10 CB50/3S + 10 CB50/3S	14 CB50/2S	14 CB50/2S	14 CB50/2S	270	1.270 x 800 x 1.950



Luce LED per armadio  
LED light for cabinet



Ogni cassetto CB50/2S o CB50/3S  
può contenere 2 vaschette estraibili.  
Each drawer CB50/2S o CB50/3S  
can contain 2 removable cups.

Esempio  
CB 400/3B



CASSETTI E VASCHE  
DRAWERS AND CUPS



STRUTTURA ESTERNO  
CASSETTIERE  
CASE



PRODOTTI IN  
MATERIALE  
RICICLABILE



# CRYSTAL BOX

armadi CB 600/4

**FERRAMENTA  
& MAGAZZINO**  
Hardware & Storage



## Armadio a pannelli scorrevoli su cuscinetti a sfera.

Struttura con n. 3 pannelli fissi affiancati sul fondo + n. 4 scorrevoli, realizzata in lamiera elettrosaldata con barre di rinforzo. Verniciata a forno con polvere epossidica.

Fornito smontato con manuale di assemblaggio e viteria.

Portata singolo pannello: kg 160 circa.

Ruote e perni silenziati in nylon.

## Cabinet with sliding panels on balls bearing.

Frame equipped with n. 3 fixed panels placed side by side on the bottom + n. 4 sliding panels, made of electrowelded reinforced plate. Made of epoxy powder coated electro-welded sheet.

Supplied disassembled with a handbook for assembly and screw and bolts.

Load capacity of each panel: 160 kg about.

Silent running nylon rollers and pins.

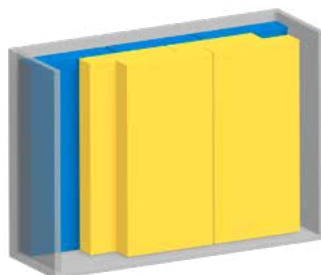

**CB 600/4**  
(201 cassetti - drawers)

- Pannello fisso con n. 5 CB50/4S + n. 4 CB50/3S x tre pannelli.  
*Fixed panel with n. 5 CB50/4S + n. 4 CB50/3S x three panels.*
- Pannello scorrevole posteriore con n. 10 CB50/3S + n. 10 CB50/3S.  
*Sliding panel with n. 10 CB50/3S + n. 10 CB50/3S.*
- Pannello scorrevole anteriore con n. 10 CB50/3S + n. 10 CB50/3S.  
*Sliding panel with n. 10 CB50/3S + n. 10 CB50/3S.*

<b>Tre pannelli fissi</b> <b>Quattro pannelli scorrevoli</b>	<b>Three fixed panels</b> <b>Four sliding panels</b>
---	---

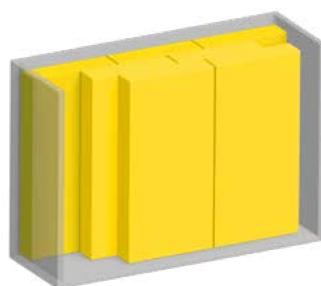

**CB 600/4A**  
(210 cassetti - drawers)

- Pannello fisso con n. 10 CB50/3S + n. 10 CB50/3S + n. 10 CB50/3S.  
*Fixed panel with n. 10 CB50/3S + n. 10 CB50/3S + n. 10 CB50/3S.*
- Pannello scorrevole posteriore con n. 10 CB50/3S + n. 10 CB50/3S.  
*Sliding panel with n. 10 CB50/3S + n. 10 CB50/3S.*
- Pannello scorrevole anteriore con n. 10 CB50/3S + n. 10 CB50/3S.  
*Sliding panel with n. 10 CB50/3S + n. 10 CB50/3S.*

<b>Tre pannelli fissi</b> <b>Quattro pannelli scorrevoli</b>	<b>Three fixed panels</b> <b>Four sliding panels</b>
---	---

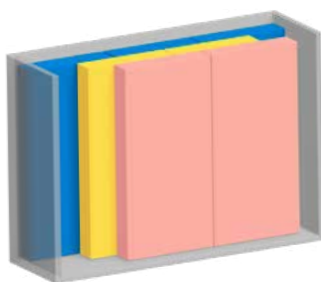

**CB 600/4B**  
(281 cassetti - drawers)

- Pannello fisso con n. 5 CB50/4S + n. 4 CB50/3S x tre pannelli.  
*Fixed panel with n. 5 CB50/4S + n. 4 CB50/3S x three panels.*
- Pannello scorrevole posteriore con n. 10 CB50/3S + n. 10 CB50/3S.  
*Sliding panel with n. 10 CB50/3S + n. 10 CB50/3S.*
- Pannello scorrevole anteriore con n. 14 CB50/2S + n. 14 CB50/2S.  
*Sliding panel with n. 14 CB50/2S + n. 14 CB50/2S.*

<b>Tre pannelli fissi</b> <b>Quattro pannelli scorrevoli</b>	<b>Three fixed panels</b> <b>Four sliding panels</b>
---	---

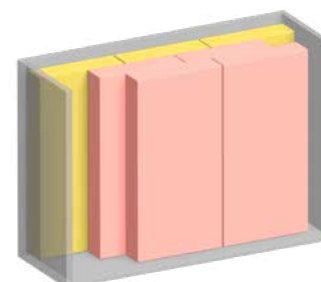

**CB 600/4C**  
(370 cassetti - drawers)

- Pannello fisso con n. 10 CB50/3S + n. 10 CB50/3S + n. 10 CB50/3S.  
*Fixed panel with n. 10 CB50/3S + n. 10 CB50/3S + n. 10 CB50/3S.*
- Pannello scorrevole posteriore con n. 14 CB50/2S + n. 14 CB50/2S.  
*Sliding panel with n. 14 CB50/2S + n. 14 CB50/2S.*
- Pannello scorrevole anteriore con n. 14 CB50/2S + n. 14 CB50/2S.  
*Sliding panel with n. 14 CB50/2S + n. 14 CB50/2S.*

<b>Tre pannelli fissi</b> <b>Quattro pannelli scorrevoli</b>	<b>Three fixed panels</b> <b>Four sliding panels</b>
---	---



Art.	3 PANNELLI FISSI 3 FIXED PANELS	2 PANN. SCORR. POST. 2 REAR SLIDING PANELS	2 PANN. SCORR. ANT. 2 SLIDING FRONT PANEL	TOT. CASSETTI TOT. DRAWERS	L x P x H
CB 600/4	(5 CB50/4S + 4 CB50/3S) x 3 PANNELLI - PANELS	10 CB50/3S + 10 CB50/3S	10 CB50/3S + 10 CB50/3S	201	1.870 x 600 x 1.950
CB 600/4A	10 CB50/3S + 10 CB50/3S +10 CB50/3S	10 CB50/3S + 10 CB50/3S	10 CB50/3S + 10 CB50/3S	210	1.870 x 600 x 1.950
CB 600/4B	(5 CB50/4S + 4 CB50/3S) x 3 PANNELLI - PANELS	10 CB50/3S + 10 CB50/3S	14 CB50/2S + 14 CB50/2S	281	1.870 x 600 x 1.950
CB 600/4C	10 CB50/3S + 10 CB50/3S +10 CB50/3S	14 CB50/2S + 14 CB50/2S	14 CB50/2S + 14 CB50/2S	370	1.870 x 600 x 1.950



Luce LED  
per armadio  
LED light  
for cabinet



Esempio  
CB 600/4B

Ogni cassetto CB50/2S o CB50/3S può contenere 2 vaschette estraibili.  
Each drawer CB50/2S o CB50/3S can contain 2 removable cups.



# CRYSTAL BOX

armadi CB 600/6

**FERRAMENTA  
& MAGAZZINO**  
Hardware & Storage



## Armadio a pannelli scorrevoli su cuscinetti a sfera.

Struttura con n. 3 pannelli fissi affiancati sul fondo + n. 6 scorrevoli, realizzata in lamiera elettrosaldada con barre di rinforzo. Verniciata a forno con polvere epossidica. Fornito smontato con manuale di assemblaggio e viteria. Portata singolo pannello: kg 160 circa. Ruote e perni silenziati in nylon.

### Cabinet with sliding panels on balls bearing.

Frame equipped with n. 3 fixed panels placed side by side on the bottom + n. 6 sliding panels, made of electrowelded reinforced plate. Made of epoxy powder coated electro-welded sheet.

Supplied disassembled with a handbook for assembly and screw and bolts. Load capacity of each panel: 160 kg about. Silent running nylon rollers and pins.

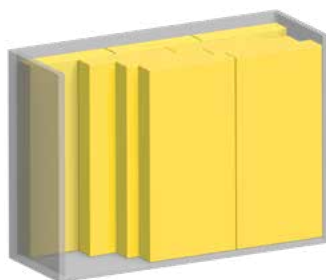

**CB 600/6**  
(261 cassetti - drawers)

- Pannello fisso con n. 10 CB50/3S + n. 10 CB50/3S + n. 10 CB50/3S.  
*Fixed panel with n. 10 CB50/3S + n. 10 CB50/3S + n. 10 CB50/3S.*
- Pannello scorrevole posteriore con n. 10 CB50/3S + n. 10 CB50/3S.  
*Sliding panel with n. 10 CB50/3S + n. 10 CB50/3S.*
- Pannello scorrevole mediano con n. 10 CB50/3S + n. 10 CB50/3S.  
*Sliding panel with n. 10 CB50/3S + n. 10 CB50/3S.*
- Pannello scorrevole anteriore con n. 10 CB50/3S + n. 10 CB50/3S.  
*Sliding panel with n. 10 CB50/3S + n. 10 CB50/3S.*

**Tre pannelli fissi  
Sei pannelli scorrevoli**

**Three fixed panels  
Six sliding panels**

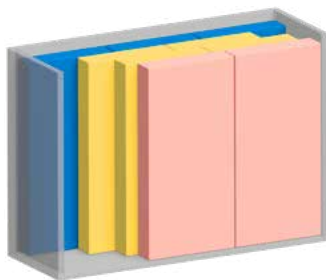

**CB 600/6A**  
(341 cassetti - drawers)

- Pannello fisso con n. 5 CB50/4S + n. 4 CB50/3S x tre pannelli.  
*Fixed panel with n. 5 CB50/4S + n. 4 CB50/3S x three panels.*
- Pannello scorrevole posteriore con n. 10 CB50/3S + n. 10 CB50/3S.  
*Sliding panel with n. 10 CB50/3S + n. 10 CB50/3S.*
- Pannello scorrevole mediano con n. 10 CB50/3S + n. 10 CB50/3S.  
*Sliding panel with n. 10 CB50/3S + n. 10 CB50/3S.*
- Pannello scorrevole anteriore con n. 14 CB50/2S + n. 14 CB50/2S.  
*Sliding panel with n. 14 CB50/2S + n. 14 CB50/2S.*

**Tre pannelli fissi  
Sei pannelli scorrevoli**

**Three fixed panels  
Six sliding panels**

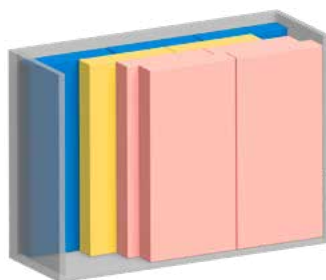

**CB 600/6B**  
(421 cassetti - drawers)

- Pannello fisso con n. 5 CB50/4S + n. 4 CB50/3S x tre pannelli.  
*Fixed panel with n. 5 CB50/4S + n. 4 CB50/3S x three panels.*
- Pannello scorrevole posteriore con n. 10 CB50/3S + n. 10 CB50/3S.  
*Sliding panel with n. 10 CB50/3S + n. 10 CB50/3S.*
- Pannello scorrevole mediano con n. 14 CB50/2S + n. 14 CB50/2S.  
*Sliding panel with n. 14 CB50/2S + n. 14 CB50/2S.*
- Pannello scorrevole anteriore con n. 14 CB50/2S + n. 14 CB50/2S.  
*Sliding panel with n. 14 CB50/2S + n. 14 CB50/2S.*

**Tre pannelli fissi  
Sei pannelli scorrevoli**

**Three fixed panels  
Six sliding panels**

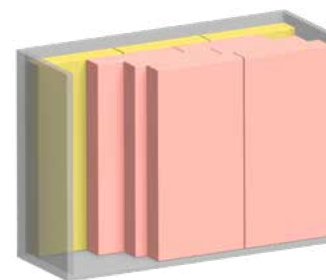

**CB 600/6C**  
(510 cassetti - drawers)

- Pannello fisso con n. 10 CB50/3S + n. 10 CB50/3S + n. 10 CB50/3S.  
*Fixed panel with n. 10 CB50/3S + n. 10 CB50/3S + n. 10 CB50/3S.*
- Pannello scorrevole posteriore con n. 14 CB50/2S + n. 14 CB50/2S.  
*Sliding panel with n. 14 CB50/2S + n. 14 CB50/2S.*
- Pannello scorrevole mediano con n. 14 CB50/2S + n. 14 CB50/2S.  
*Sliding panel with n. 14 CB50/2S + n. 14 CB50/2S.*
- Pannello scorrevole anteriore con n. 14 CB50/2S + n. 14 CB50/2S.  
*Sliding panel with n. 14 CB50/2S + n. 14 CB50/2S.*

**Tre pannelli fissi  
Sei pannelli scorrevoli**

**Three fixed panels  
Six sliding panels**

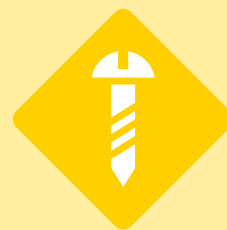

Art.	3 PANNELLI FISSI 3 FIXED PANELS	2 PANN. SCORR. POST. 2 REAR SLIDING PANELS	2 PANN. SCORR. MEDIANO 2 REAR SLIDING PANELS	2 PANN. SCORR. ANT. 2 SLIDING FRONT PANEL	TOT. CASSETTI TOT. DRAWERS	L x P x H
CB 600/6	(10 CB50/3S) x 3 PANNELLI - PANELS	10 CB50/3S + 10 CB50/3S	10 CB50/3S + 10 CB50/3S	10 CB50/3S + 10 CB50/3S	261	1.870 x 800 x 1.950
CB 600/6A	(5 CB50/4S + 4 CB50/3S) x 3 PANNELLI - PANELS	10 CB50/3S + 10 CB50/3S	10 CB50/3S + 10 CB50/3S	14 CB50/2S + 14 CB50/2S	341	1.870 x 800 x 1.950
CB 600/6B	(5 CB50/4S + 4 CB50/3S) x 3 PANNELLI - PANELS	10 CB50/3S + 10 CB50/3S	14 CB50/2S + 14 CB50/2S	14 CB50/2S + 14 CB50/2S	421	1.870 x 800 x 1.950
CB 600/6C	(10 CB50/3S) x 3 PANNELLI - PANELS	14 CB50/2S + 14 CB50/2S	14 CB50/2S + 14 CB50/2S	14 CB50/2S + 14 CB50/2S	510	1.870 x 800 x 1.950



Luce LED  
per armadio  
LED light  
for cabinet



Esempio  
CB 600/6A

Ogni cassetto CB50/2S o CB50/3S può contenere 2 vaschette estraibili.  
Each drawer CB50/2S o CB50/3S can contain 2 removable cups.



# CRYSTAL BOX

carrelli

## FERRAMENTA & MAGAZZINO

Hardware & Storage



**Robusto e pratico carrello per esigenze di magazzinaggio mobile.** Realizzato in lamiera elettrosaldata e verniciato a forno in polvere epossidica di colore grigio (simil Ral 7035). Dotato di n. 4 ruote gommare di cui 2 piroettanti (una con fermo). Forniti smontati e minuterie per l'assemblaggio.

***Strong and practical wheeled trolley for storage.***

*Made of epoxy powder coated electro-welded sheet, in grey colour (similar to RAL 7035).*

*Complete with 4 rubber wheels: 2 fixed and 2 swivel castors (1 braked). Supplied disassembled with assembly screws and bolts.*



Maniglia di trasporto.  
*Carrying handle.*



Ruota con fermo.  
*Braked castor.*



Opzionale cassetto.  
*Optional draws.*



Esempio di allestimento e colori

●  
RAL 7035  
(STRUTTURA - FRAME)



Art.	DESCRIZIONE DESCRIPTION	L x P x H
CB 30	carrello in metallo CB 30. metal trolley CB 30.	610 x 610 x 1.355 (utile 1.040)

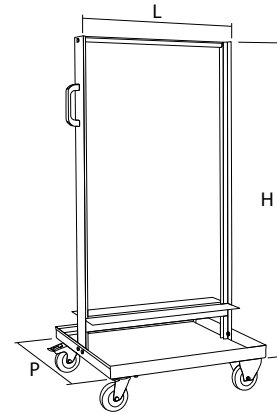

**CB 30**  
(prodotto privo di cassettiere)  
(item supplied without drawers)



PRODOTTI IN  
MATERIALE  
RICICLABILE

# C-MINI

## cassettiere componibili MINI

### FERRAMENTA & MAGAZZINO

Hardware & Storage

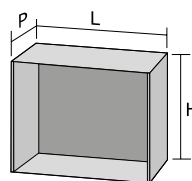

art	L	H	P	Imballo pezzi Pack quantity	Cassetti Drawers
A	225	169	133	6	24 cassetti: l. 48 - p. 114,5 - h. 24
T/A	225	169	133	6	24 cassetti: l. 48 - p. 114,5 - h. 24
A1	225	169	133	6	12 cassetti: l. 48 - p. 114,5 - h. 50
T/A1	225	169	133	6	12 cassetti: l. 48 - p. 114,5 - h. 50
B	225	169	133	6	12 cassetti: l. 103 - p. 114,5 - h. 24
T/B	225	169	133	6	12 cassetti: l. 103 - p. 114,5 - h. 24
C	225	169	133	6	6 cassetti: l. 103 - p. 114,5 - h. 50
T/C	225	169	133	6	6 cassetti: l. 103 - p. 114,5 - h. 50
D	225	169	133	6	3 cassetti: l. 214 - p. 114,5 - h. 50
T/D	225	169	133	6	3 cassetti: l. 214 - p. 114,5 - h. 50
M	225	169	133	6	4 cassetti: l. 48 - p. 114,5 - h. 24 2 cassetti: l. 48 - p. 114,5 - h. 50 2 cassetti: l. 103 - p. 114,5 - h. 24 1 cassetto: l. 103 - p. 114,5 - h. 50 1 cassetto: l. 214 - p. 114,5 - h. 50
T/M	225	169	133	6	4 cassetti: l. 48 - p. 114,5 - h. 24 2 cassetti: l. 48 - p. 114,5 - h. 50 2 cassetti: l. 103 - p. 114,5 - h. 24 1 cassetto: l. 103 - p. 114,5 - h. 50 1 cassetto: l. 214 - p. 114,5 - h. 50

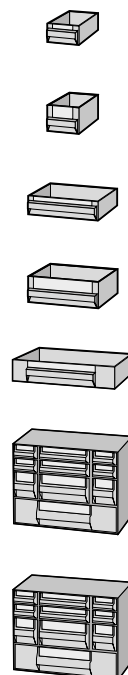

### VASCHE

art	L	H	P
A	47	22	37
B	37	22	27
C	56	46	51
A1	56	46	47
D	110	46	56

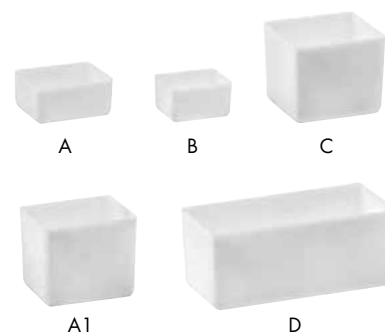

BIANCO (BI)

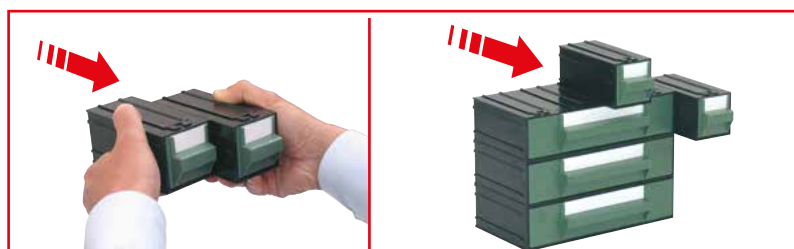

VERDE (VE)

TRASPARENTE (TR)



A



A1



B



C



D



M



T/A



T/A1



T/B



T/C



T/D



T/M

CARTELLINI IN DOTAZIONE STANDARD - TAGS INCLUDED



PRODOTTI IN  
MATERIALE  
RICICLABILE



# C-MIDI

## cassettiere componibili MIDI

### FERRAMENTA & MAGAZZINO Hardware & Storage

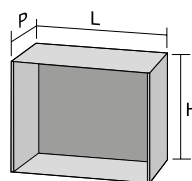

art	L	H	P	Imballo pezzi Pack quantity	Cassetti Drawers
T/42	225	225	225	8	2 cassetti: l. 212 - p. 198 - h. 103
T/43	225	225	225	8	4 cassetti: l. 212 - p. 198 - h. 48
T/44	225	225	225	8	4 cassetti: l. 101- p. 198 - h. 103
T/45	225	225	225	8	4 cassetti: l. 101- p. 198 - h. 103 con 8 separatori estraibili

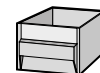
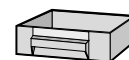

TRASPARENTE (TR)



T/42



T/43



T/44



T/45

CARTELLINI IN DOTAZIONE STANDARD - TAGS INCLUDED



PRODOTTI IN  
MATERIALE  
RICICLABILE

# C-MAXI

## cassettiere componibili MAXI

### FERRAMENTA & MAGAZZINO

Hardware & Storage

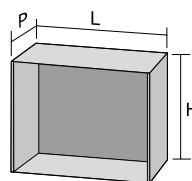

art	L	H	P	Imballo pezzi Pack quantity	Cassetti Drawers	
* L	225	228	263	8	6 cassetti: l. 101 - p. 241 - h. 67 con 12 separatori estraibili trasparenti	
T/L	225	228	263	8	6 cassetti: l. 101 - p. 241 - h. 67 con 12 separatori estraibili trasparenti	
* E	340	340	270	1	6 cassetti: l. 155 - p. 241 - h. 100	
T/E	340	340	270	1	6 cassetti: l. 155 - p. 241 - h. 100	
* F	562	228	390	1	4 cassetti: l. 266 - p. 357 - h. 100	
T/F	562	228	390	1	4 cassetti: l. 266 - p. 357 - h. 100	
H/3	562	228	390	1	6 cassetti: l. 266 - p. 358 - h. 65	
T/3	562	228	390	1	6 cassetti: l. 266 - p. 358 - h. 65	
* G	393	228	390	1	2 cassetti: l. 376 - p. 357 - h. 100	
* F/T	562	228	390	1	4 cassetti: l. 266 - p. 357 - h. 100	

\* CARTELLINI E COPRI CARTELLINI IN DOTAZIONE STANDARD

\* TAGS E TAGS COVER INCLUDED

### Cassettiere MAXI

maggiore resistenza al carico, corpo esterno per ogni cassetto.

### Modules MAXI

High load resistance and bodies drawers.



●  
VERDE (VE)

○  
TRASPARENTE (TR)



H/3



Espositore per F - G  
Display for F - G



L



E



F



F/T

Cassetti con separatore  
longitudinale fisso.  
Drawers with longitudinal  
fixed divisor.



G



T/L



T/E

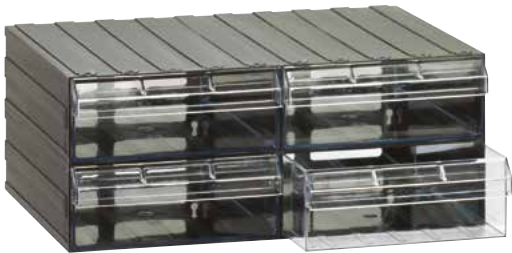

T/F



T/3



PRODOTTI IN  
MATERIALE  
RICICLABILE

# C-MAXI

## cassettiere componibili MAXI

### FERRAMENTA & MAGAZZINO Hardware & Storage

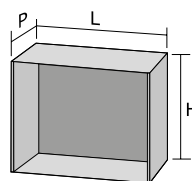

art	L	H	P	Imballo pezzi Pack quantity	Cassetti Drawers
MOBIL 1	225	450	323	1	4 cassetti: l. 210 - p. 289 - h. 103
MOBIL 101	225	450	323	1	4 cassetti: l. 210 - p. 289 - h. 103
MOBIL 2	169	228	323	8	2 cassetti: l. 155 - p. 289 - h. 103
MOBIL 102	169	228	323	8	2 cassetti: l. 155 - p. 289 - h. 103
MOBIL 3	562	228	390	1	4 cassetti: l. 266 - p. 360 - h. 103
MOBIL 103	562	228	390	1	4 cassetti: l. 266 - p. 360 - h. 103



CARTELLINI IN DOTAZIONE STANDARD - TAGS INCLUDED



VERDE (VE)



TRASPARENTE (TR)



**MOBIL 1**



**MOBIL 2**



**MOBIL 1/T**

Composizione da 4 cassetti con separatore Longitudinale fisso e 4 separatori estraibili  
*Fixed divider and 4 removable dividers*



**MOBIL 3**



**MOBIL 101**



**MOBIL 102**



**MOBIL 103**



PRODOTTI IN  
MATERIALE  
RICICLABILE

### FERRAMENTA & MAGAZZINO

Hardware & Storage



## ESEMPI DI ALLESTIMENTO:

**F1 - F2 - F3 per cassettiere: F - T/ F - F/ T - MOBIL 3 - MOBIL 103**

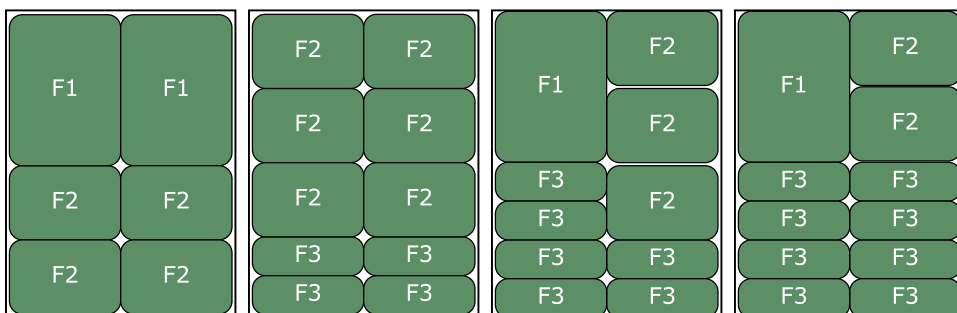
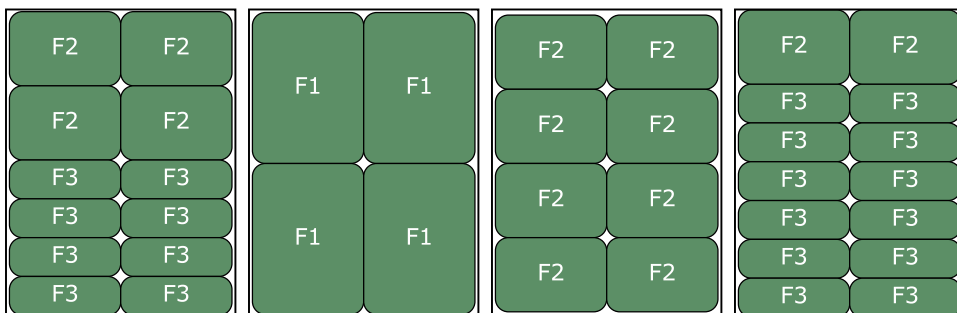

**H1 - H2 - H3 per cassettiere: H/ 3 - T/ 3**

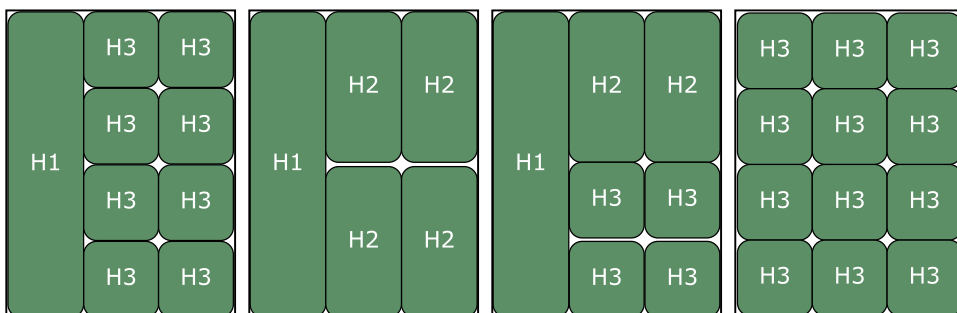

**E per cassettiere: E- T/E**

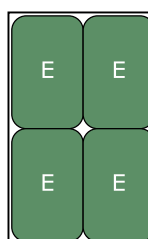

●  
VERDE (VE)

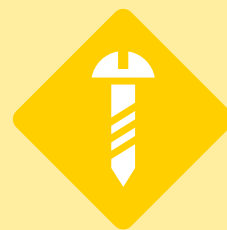

art	L	H	P
E	117	91	74
F1	175	91	129
F2	129	91	86
F3	129	91	45

art	L	H	P
G1	175	91	108
H1	355	55	88
H2	175	55	88
H3	87	55	88

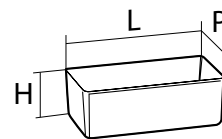

F1



F2



F3



H1



H2



H3



E



G1



PRODOTTI IN  
MATERIALE  
RICICLABILE



# C-MAXI

## cassettiere componibili MAXI

### FERRAMENTA & MAGAZZINO

Hardware & Storage

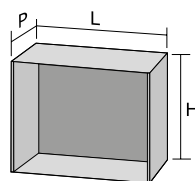

art	L	H	P	Imballo pezzi Pack quantity	Cassetti Drawers
S40	238	262	423	1	2 cassetti: l. 220 - p. 390 - h. 120
T40	238	262	423	1	2 cassetti: l. 220 - p. 390 - h. 120
S40/T	238	262	423	1	2 cassetti: l. 220 - p. 390 - h. 120

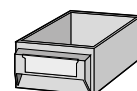

CARTELLINI IN DOTAZIONE STANDARD - TAGS INCLUDED

### S40 - T40 - S40/T

cassettiere non componibili con le altre serie, realizzate per utilizzo su scaffali 1000 mm x 400 mm

### S40 - T40 - S40T

modules madia structure not compatible with other series, designed for use on shelves 1000 mm x 400 mm

## BASI per C-MAXI

art	L	H	P	Imballo pezzi Pack quantity
BASE E	165	70	250	1
BASE F	280	70	370	1
BASE G	390	70	370	1

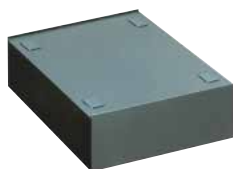

### BASE E

Base E per composizioni E - T/ E  
Base E for modules E - T/ E



### BASE F

Base F per composizioni F - F/ T - T/ F  
H/ 3 - T/ 3 - MOBIL 3 - MOBIL 103  
Base F for modules F - F/ T - T/ F  
H/ 3 - T/ 3 - MOBIL 3 - MOBIL 103

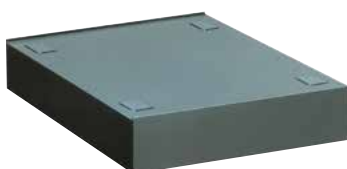

### BASE G

Base G per composizione G  
Base G for module G



VERDE (VE)



TRASPARENTE (TR)



S40



T40



S40/T

con 3 separatori  
estraibili  
with 3 removable  
dividers



4 cassetti affiancati consentono di utilizzare senza perdite di spazio la luce frontale nominale di 1.000 mm. e la profondità di 400 mm.

4 drawers, one close to the other, allow to exploit a linear space of 1.000 mm. and a width of 400 mm.



PRODOTTI IN  
MATERIALE  
RICICLABILE

# CLASS

organizer

## FERRAMENTA & MAGAZZINO

Hardware & Storage



art	L	H	P	H utile	Imballo pezzi Pack quantity
CLASS 9	130	26	86	20,5	48
CLASS 9VA	130	26	86	19	48
CLASS 10	180	40	125	35,5	36
CLASS 11	268	50	125	45	24
CLASS 12	268	50	125	42,5	24
CLASS 13	268	50	188	45	18
CLASS 14	268	50	188	43	18

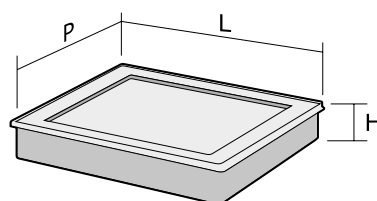

TRASPARENTE (TR)



**CLASS 9**

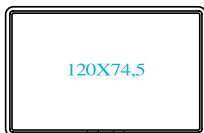

**CLASS 9VA**  
con 6 vaschette estraibili

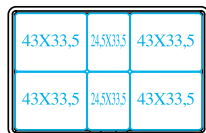

**CLASS 10**

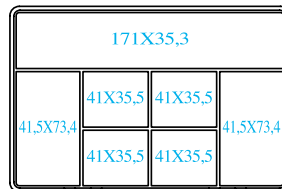

**CLASS 11**

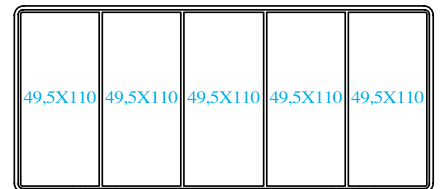

**CLASS 12**  
con 10 vaschette estraibili

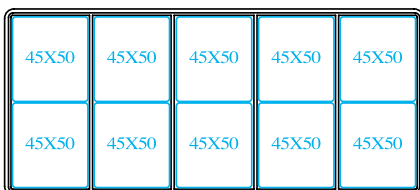

**CLASS 13**

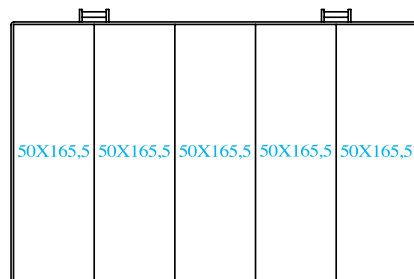

**CLASS 14**  
con 15 vaschette estraibili

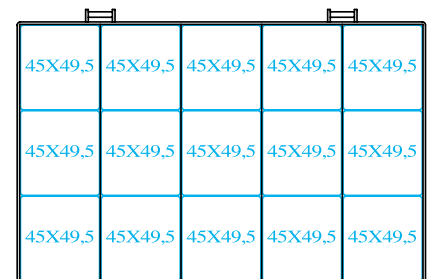

# CLASS

organizer

## FERRAMENTA & MAGAZZINO

Hardware & Storage

art	L	H	P	H utile	Imballo pezzi <i>Pack quantity</i>
CLASS 18	190	40	155	30	16
CLASS 19	190	40	155	27,5	16
CLASS 20	240	55	186	45	12
CLASS 22	240	55	186	42	12

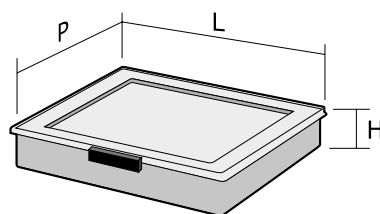

CHIUSURA DI SICUREZZA  
SECURITY CLOSURE



**CLASS 18**

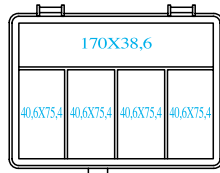

**CLASS 19**  
Con 12 vaschette estraibili

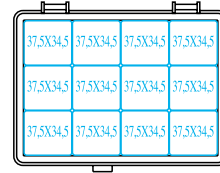

**CLASS 20**

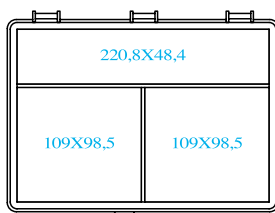

**CLASS 22**  
con 8 vaschette estraibili

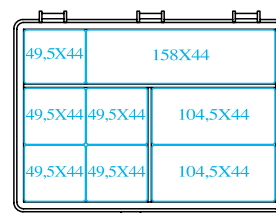

# CLASS

## organizer

### FERRAMENTA & MAGAZZINO

Hardware & Storage



art	L	H	P	H utile	Imballo pezzi Pack quantity
CLASS 30	325	55	260	45	6
CLASS 31	325	55	260	45	6
CLASS 32	325	55	260	42	6
CLASS 41	400	70	340	56	5
CLASS 42	400	70	340	53	5

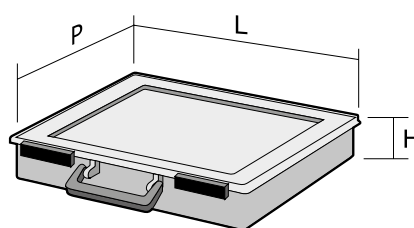

### VASCHETTE CLASS



**CLASS 1**  
L. 55 - P. 50 - H. 45



**CLASS 2**  
L. 110 - P. 50 - H. 45



**CLASS 3**  
L. 165 - P. 50 - H. 45



**CLASS 4**  
L. 40 - P. 43 - H. 30



**CLASS 5**  
L. 76 - P. 76 - H. 57



**CLASS 6**  
L. 152 - P. 76 - H. 57



**CLASS 7**  
L. 228 - P. 76 - H. 57



**CLASS 8**  
L. 152 - P. 152 - H. 57

○  
TRASPARENTE (TR)

●  
BLU (BL)



**CLASS 30**

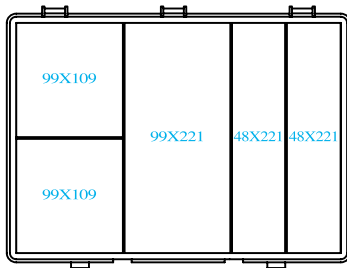

**CLASS 31**

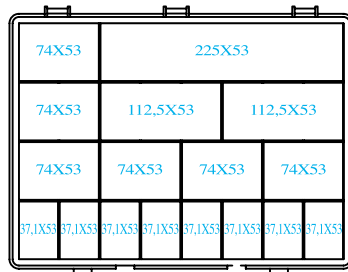

**CLASS 32**  
con 16 vaschette estraibili

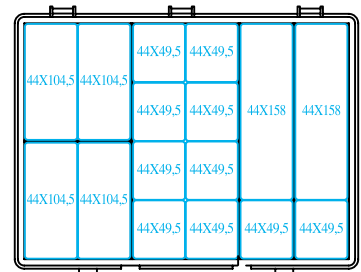

**CLASS 41**  
con 12 divisori estraibili

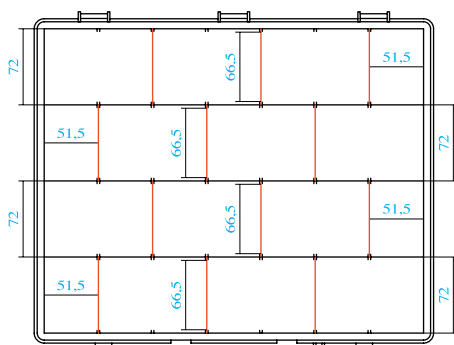

**CLASS 42**  
con 10 vaschette estraibili

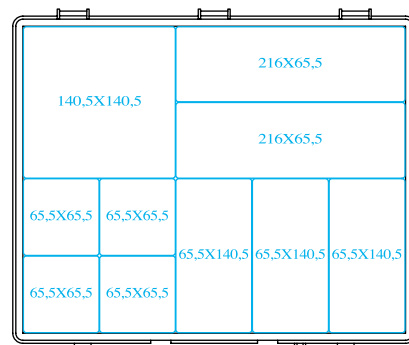



# ESPACE

## cassettiere

### FERRAMENTA & MAGAZZINO

Hardware & Storage

art	L	H	P	Imballo pezzi Pack quantity	Cassetti Drawers
ESPACE 12	220	180	150	12	12 cassetti: l. 60 - p. 137 - h. 37
ESPACE 20	290	225	150	10	20 cassetti: l. 60 - p. 137 - h. 37
ESPACE 30	365	270	150	4	30 cassetti: l. 60 - p. 137 - h. 37

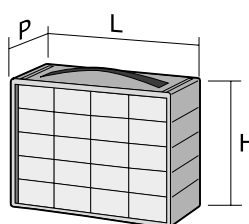



**ESPACE 12**  
12 cassette con 12 divisori estraibili



**ESPACE 20**  
20 cassette con 20 divisori estraibili



**ESPACE 30**  
30 cassette con 30 divisori estraibili



PRODOTTI IN  
MATERIALE  
RICICLABILE



68

**BIDONI  
CARRELLATI 120 l**



70

**BIDONI  
CARRELLATI 240 l**



73

**BIDONI  
CARRELLATI 360 l**



74

**CASSONETTI  
4 RUOTE 660 l**



76

**CASSONETTI  
4 RUOTE 770 l**



78

**CASSONETTI  
4 RUOTE 1100 l**



80

**ECOLOGY 25/35**



82

**PULIZIA**



83

**DUSTY**



# PULIZIA & RACCOLTA DIFFERENZIATA

## Cleaning & Waste collection



**BIDONI 80**



**BIDONI 100**



**BIDONI  
100 PUSH**



**NELLO**



**TRESPOLO**



**ECO-AIR 4**



**BIDONI 91**



**BIDONI INDUSTRIALI  
NERI**



**BIDONI INDUSTRIALI  
VERDI**

# BIDONI CARRELLATI 120 l

# BIDONI CARRELLATI BICOLORE 120 l

## PULIZIA & RACCOLTA DIFFERENZIATA

Cleaning & waste collection



**1/ 120**

Anello fermasacco per bidone 120 l  
120 l bin liners bags

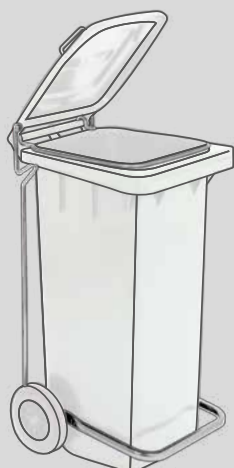

**1204**

Kit pedale + anello per bidone 120 l  
120 l bin pedal and ring



**95/ 120**

Sacchetti immondizia per bidone raccolta differenziata 120 l  
120 l bin liners bags

Bidone carrellato 120 litri a due ruote per la raccolta differenziata. Prodotto realizzato in HDPE (polietilene alta densità) 100% riciclabile, stabilizzato UV per utilizzo in ambienti esterni. Capacità di carico max 60 kg. Predisposto per presa frontale a pettine a norma DIN. Dotato di due ruote in gomma diametro 200 mm. Grande maneggevolezza, maniglie ergonomiche, bordi e spigoli arrotondati. Coperchio con apertura a libro e bordo anti infiltrazione, sede per alloggiamento microchip, elevata resistenza meccanica ed agli agenti chimici, facile da pulire e sanificare. Disponibile in 7 colori.

*Two-wheeled 120 liter mobile waste bin for differential refuse collection. Product made of 100% recyclable HDPE (high density polyethylene), UV stabilized for outdoor use. Max load capacity 60 kg. Prepared for DIN standard frontal socket. Equipped with two 200 mm diameter rubber wheels. Easy handling, ergonomic handles, rounded corners and edges. Lid with book opening and anti-infiltration edge, seat for microchip housing, high mechanical and chemical resistance, easy to clean and sanitize. Available in 7 colors.*



UNI EN 840  
Certificato  
Certified

Carrellato	120 litri
A	930 mm
B	875 mm
C	485 mm
D	550 mm
E	480 mm
F	355 mm
G	480 mm
PESO / WEIGHT	9 Kg

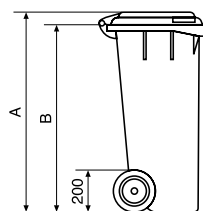
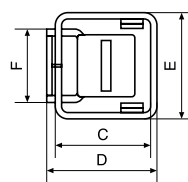

**1/120/5**  
120 litri



PRODOTTI IN  
MATERIALE  
RICICLABILE



BIANCO LATTE (BIL)



GIALLO (GIA)



VERDE SCURO (VES)



BRUNO BIDONE (BRB)



BLU BIDONE (BLB)



ROSSO BIDONE (ROB)



GRIGIO BIDONE (GRB)



Bidone carrellato 120 litri bicolore a due ruote per la raccolta differenziata.  
 Prodotto realizzato in HDPE (polietilene alta densità) 100% riciclabile, stabilizzato UV per utilizzo in ambienti esterni.  
 Capacità di carico max 60 kg. Predisposto per presa frontale a pettine a norma DIN.  
 Dotato di due ruote in gomma diametro 200 mm.  
 Grande maneggevolezza, maniglie ergonomiche, bordi e spigoli arrotondati.  
 Coperchio con apertura a libro e bordo anti infiltrazione, sede per alloggiamento microchip, elevata resistenza meccanica ed agli agenti chimici, facile da pulire e sanificare.  
 Bidone grigio e coperchi in 4 colori differenti.

*Two-wheeled bicolor 120 liter mobile waste bin for differential refuse collection  
 Product made of 100% recyclable HDPE (high density polyethylene), UV stabilized for outdoor use. Max load capacity 60 kg.  
 Prepared for DIN standard frontal socket.  
 Equipped with two 200 mm diameter rubber wheels. Easy handling, ergonomic handles, rounded corners and edges.  
 Lid with book opening and anti-infiltration edge, seat for microchip housing, high mechanical and chemical resistance, easy to clean and sanitize.  
 Available with grey body and lid in 4 different colors.*



Carrellato	120 litri
A	930 mm
B	875 mm
C	485 mm
D	550 mm
E	480 mm
F	355 mm
G	480 mm
PESO / WEIGHT	9 Kg

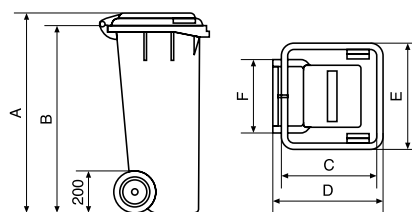

**1/ 120**

Anello fermasacco per bidone bicolore 120 l  
 120 l bin liners bags



**95/ 120**

Sacchetti immondizia per bidone raccolta differenziata 120 l  
 120 l bin liners bags

**1/120/5**  
 120 litri



UNI EN 840  
 Certificato  
 Certified



Adesivi in dotazione (non applicati)  
 Supplied stickers (not applied)



**1204**

Kit pedale + anello per bidone 120 l  
 120 l bin pedal and ring



GRIGIO-GIALLO  
 (GRB-GIA)



GRIGIO-VERDE  
 (GRB-VES)



GRIGIO-BLU  
 (GRB-BLB)



GRIGIO-ROSSO  
 (GRB-ROB)

# BIDONI CARRELLATI 240 l

# BIDONI CARRELLATI BICOLORE 240 l

## PULIZIA & RACCOLTA DIFFERENZIATA

Cleaning & waste collection



**1/240**

Anello fermasacco per bidone 240 l  
240 l bin liners bags

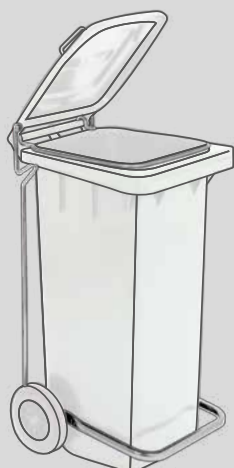

**2404**

Kit pedale + anello per bidone 240 l  
240 l bin pedal and ring



**95/240**

Sacchetti immondizia per bidone raccolta differenziata 240 l  
2400 l bin liners bags

Bidone carrellato 240 litri a due ruote per la raccolta differenziata. Prodotto realizzato in HDPE (polietilene alta densità) 100% riciclabile, stabilizzato UV per utilizzo in ambienti esterni. Capacità di carico max 116 kg. Predisposto per presa frontale a pettine a norma DIN. Dotato di due ruote in gomma diametro 200 mm. Grande maneggevolezza, maniglie ergonomiche, bordi e spigoli arrotondati. Coperchio con apertura a libro e bordo anti infiltrazione, sede per alloggiamento microchip, elevata resistenza meccanica ed agli agenti chimici, facile da pulire e sanificare. Disponibile in 7 colori.

*Two-wheeled 240 liter mobile waste bin for differential refuse collection. Product made of 100% recyclable HDPE (high density polyethylene), UV stabilized for outdoor use. Max load capacity 116 kg. Prepared for DIN standard frontal socket. Equipped with two 200 mm diameter rubber wheels. Easy handling, ergonomic handles, rounded corners and edges. Lid with book opening and anti-infiltration edge, seat for microchip housing, high mechanical and chemical resistance, easy to clean and sanitize. Available in 7 colors.*



UNI EN 840  
Certificato  
Certified

Carrellato	240 litri
A	1070 mm
B	995 mm
C	655 mm
D	730 mm
E	580 mm
F	420 mm
G	570 mm
PESO / WEIGHT	13 Kg

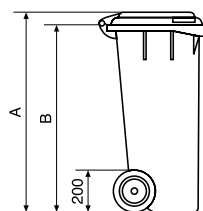
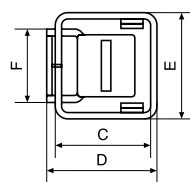

**1/240/5**  
240 litri



PRODOTTI IN  
MATERIALE  
RICICLABILE



BIANCO LATTE (BIL)



GIALLO (GIA)



VERDE SCURO (VES)



BRUNO BIDONE (BRB)



BLU BIDONE (BLB)



ROSSO BIDONE (ROB)



GRIGIO BIDONE (GRB)



Bidone carrellato 240 litri bicolore a due ruote per la raccolta differenziata.  
 Prodotto realizzato in HDPE (polietilene alta densità) 100% riciclabile, stabilizzato UV per utilizzo in ambienti esterni.  
 Capacità di carico max 116 kg. Predisposto per presa frontale a pettine a norma DIN.  
 Dotato di due ruote in gomma diametro 200 mm.  
 Grande maneggevolezza, maniglie ergonomiche, bordi e spigoli arrotondati.  
 Coperchio con apertura a libro e bordo anti infiltrazione, sede per alloggiamento microchip, elevata resistenza meccanica ed agli agenti chimici, facile da pulire e sanificare.  
 Bidone grigio e coperchi in 4 colori differenti.

*Two-wheeled bicolor 240 liter mobile waste bin for differential refuse collection  
 Product made of 100% recyclable HDPE (high density polyethylene), UV stabilized for outdoor use. Max load capacity 116 kg.  
 Prepared for DIN standard frontal socket.  
 Equipped with two 200 mm diameter rubber wheels. Easy handling, ergonomic handles, rounded corners and edges. Lid with book opening and anti-infiltration edge, seat for microchip housing, high mechanical and chemical resistance, easy to clean and sanitize.  
 Available with grey body and lid in 4 different colors.*



Carrellato	240 litri
A	1070 mm
B	995 mm
C	655 mm
D	730 mm
E	580 mm
F	420 mm
G	570 mm
PESO / WEIGHT	13 Kg

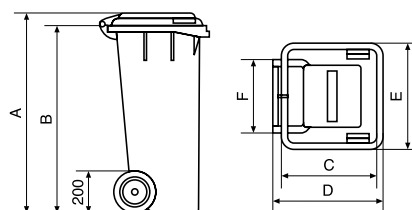

**1/ 240**

Anello fermasacco per bidone bicolore 240 l  
 240 l bin liners bags



**95/ 240**

Sacchetti immondizia per bidone raccolta differenziata 120 l  
 120 l bin liners bags

**1/240/5**  
 240 litri



UNI EN 840  
 Certificato  
 Certified



Adesivi in dotazione (non applicati)  
 Supplied stickers (not applied)

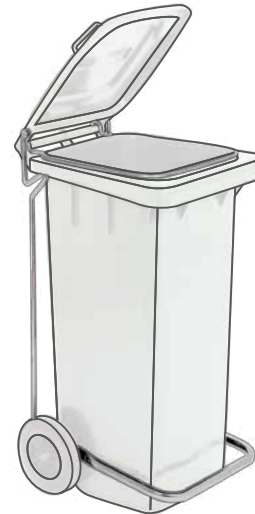

**2204**

Kit pedale + anello per bidone 240 l  
 240 l bin pedal and ring



GRIGIO-GIALLO  
 (GRB-GIA)



GRIGIO-VERDE  
 (GRB-VES)



GRIGIO-BLU  
 (GRB-BLB)



GRIGIO-ROSSO  
 (GRB-ROB)



# SERRATURA GRAVITAZIONALE

per bidoni carrellati 120/240 l

## PULIZIA & RACCOLTA DIFFERENZIATA

Cleaning & waste  
collection



Il sistema a serratura gravitazionale consente allo stesso tempo:

- l'apertura e la chiusura del coperchio del bidone solamente al possessore della chiave;
- lo svuotamento del bidone da parte degli addetti alla raccolta dei rifiuti anche con serratura chiusa in quanto l'apertura del contenitore avviene in automatico una volta raggiunta una certa inclinazione (>90°) in fase di svuotamento e la chiusura viene ripristinata una volta che il contenitore viene riportato in posizione.

Il sistema rende inoltre possibile aprire il bidone dall'interno anche con serratura chiusa (per situazioni di emergenza) e non consente l'apertura accidentale del bidone in caso di rovesciamento, urti e/o atti di vandalismo.

Il kit è formato da:

- un cupolotto con serratura integrata da montare esternamente sul coperchio;
- un elemento con gancio da collocare sulla parte interna del coperchio;
- un corpo inferiore da installare nella parte interna della vasca;
- due chiavi per aprire/chiusure la serratura;
- le dime per individuare la posizione dei fori e consentire il montaggio del sistema.

*The gravitational lock system allows at the same time:*

- the opening and closing of the lid of the bin only to the holder of the key;
- the emptying of the bin by the waste collectors even with the lock closed as the opening of the container takes place automatically once a certain inclination (>90°) is reached during the emptying phase and the closure is restored once the container is returned to position.

*The system also makes it possible to open the bin from the inside even with the lock closed (for emergency situations) and does not allow accidental opening of the bin in case of overturning, collisions and / or vandalism.*

*The kit consists of:*

- a dome with integrated lock to be mounted externally on the lid;
- an element with a hook to be placed on the inside of the lid;
- a lower body to be installed in the internal part of the tank;
- two keys to open / close the lock;
- the templates to identify the position of the holes to allow to assembly the kit on the bin.



**1/111**  
120 - 240 litri



# BIDONI CARRELLATI

## 360 l



**Bidone carrellato 360 litri a due ruote per la raccolta differenziata.**

Prodotto realizzato in HDPE (polietilene alta densità) 100% riciclabile, stabilizzato UV per utilizzo in ambienti esterni. Capacità di carico max 160 kg Predisposto per presa frontale a pettine a norma DIN. Dotato di due ruote in gomma diametro 200 mm alloggiabili in due distinte posizioni per un'agile movimentazione e stabilità. Grande maneggevolezza, maniglie ergonomiche, bordi e spigoli arrotondati. Coperchio con apertura a libro e bordo anti infiltrazione, sede per alloggiamento microchip, elevata resistenza meccanica ed agli agenti chimici, facile da pulire e sanificare. Disponibile in 5 colori.

Versione bicolore con bidone di colore grigio e coperchi in 4 colori differenti.

*Two-wheeled 360 liter mobile waste bin for differential refuse collection.*

*Product made of 100% recyclable HDPE (high density polyethylene), UV stabilized for outdoor use. Max load capacity 160 kg. Prepared for DIN standard frontal socket. Equipped with two 200 mm diameter rubber wheels that can be housed in two distinct positions to move the bin in an easy way and have great stability. Easy handling, ergonomic handles, rounded corners and edges. Lid with book opening and anti-infiltration edge, seat for microchip housing, high mechanical and chemical resistance, easy to clean and sanitize.*

*Available in 5 colors.*

*Bicolore available with grey body and lid in 4 different colors.*

A	1099
B	1015
C	880
D	596
PESO / WEIGHT	15,5 Kg

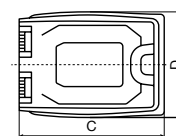
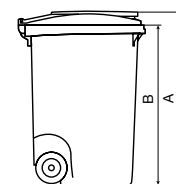

**1/360/5**  
360 litri



● GRIGIO BIDONE (GRB) ● GIALLO (GIA) ● ROSSO BIDONE/VERDE BIDONE (ROB) ● VERDE (VEB) ● BLU BIDONE (BLB)



●● GRIGIO-GIALLO (GRB-GIA) ●● GRIGIO-ROSSO (GRB-ROB) ●● GRIGIO-VERDE (GRB-VEB) ●● GRIGIO-BLU (GRB-BLB)

# CASSONETTI 4 RUOTE 660 l

# CASSONETTI 4 RUOTE BICOLORE 660 l

## PULIZIA & RACCOLTA DIFFERENZIATA

Cleaning & waste  
collection



TÜV Rheinland®

UNI EN 840  
Certificato  
Certified

**Cassonetto carrellato 4 ruote capacità 660 litri con coperchio piano.** Prodotto realizzato in HDPE (polietilene alta densità) 100% riciclabile stabilizzato UV per utilizzo in ambienti esterni.

Capacità di carico max 310 kg. Predisposto per presa frontale a pettine a norma DIN, dotato di quattro ruote girevoli (due delle quali con freno) con battistrada in gomma diametro 200. Grande maneggevolezza, assenza di bordi taglienti e spigoli smussati.

Dotato di maniglie ergonomiche per la movimentazione, tappo sul fondo per una corretta pulizia e sanificazione.

Coperchio piano con apertura a libro ed impugnatura a labbro e bordo anti infiltrazione, sede per alloggiamento microchip.

Elevata resistenza meccanica ed agli agenti chimici.

Disponibile in 4 colori.

Disponibile versione bicolor con vasca di colore grigio e coperchi in 3 colori differenti.

*Four-wheeled 660 liter mobile waste bin for differential refuse collection with flat lid. Product made of 100% recyclable HDPE (high density polyethylene), UV stabilized for outdoor use. Max load capacity 310 kg. Prepared for DIN standard frontal socket, equipped with four 200 mm diameter rubber caster wheels (two of them with braking system). Easy handling, ergonomic handles, rounded corners and edges. Equipped with ergonomic handles for handling, cap on the bottom for proper cleaning and sanitization. Flat lid with book opening and lip handle and anti-infiltration edge, seat for microchip housing. High mechanical and chemical resistance.*

*Available in 4 colors.*

*Bicolor available with grey body and lid in 3 different colors.*



1/660/5  
660 litri

GRIGIO BIDONE  
(GRB)

GIALLO  
(GIA)

VERDE BIDONE  
(VEB)

BLU BIDONE  
(BLB)



PRODOTTI IN  
MATERIALE  
RICICLABILE



A	778
B	1228
C	1105
D	1370
E	1270
F	1200
G	836
PESO / WEIGHT	40 Kg

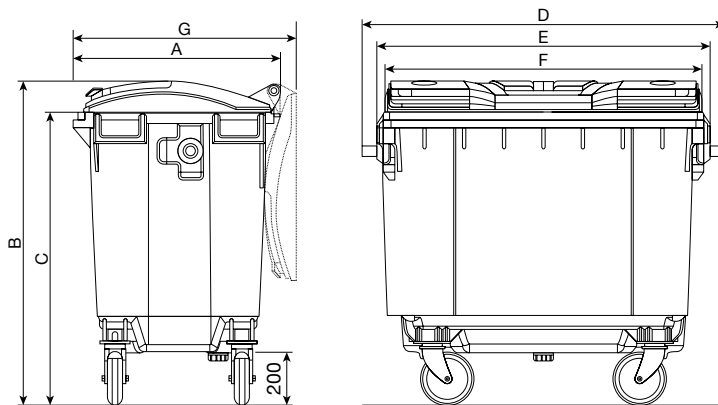

**6604**

Kit pedale per cassonetto 660 l  
660 l bin pedal



**1/660/5**  
660 litri

  
GRIGIO-GIALLO  
(GRB-GIA)

  
GRIGIO-VERDE  
(GRB-VEB)

  
GRIGIO-BLU  
(GRB-BLB)



PRODOTTI IN  
MATERIALE  
RICICLABILE

# CASSONETTI 4 RUOTE 770 l

# CASSONETTI 4 RUOTE BICOLORE 770 l

## PULIZIA & RACCOLTA DIFFERENZIATA

Cleaning & waste  
collection



TÜV Rheinland®

UNI EN 840  
Certificato  
Certified

**Cassonetto carrellato 4 ruote capacità 770 litri con coperchio piano.** Prodotto realizzato in HDPE (polietilene alta densità) 100% riciclabile stabilizzato UV per utilizzo in ambienti esterni.

Capacità di carico max 360 kg. Predisposto per presa frontale a pettine a norma DIN, dotato di quattro ruote girevoli (due delle quali con freno) con battistrada in gomma diametro 200. Grande maneggevolezza, assenza di bordi taglienti e spigoli smussati. Dotato di maniglie ergonomiche per la movimentazione, tappo sul fondo per una corretta pulizia e sanificazione. Coperchio piano con apertura a libro ed impugnatura a labbro e bordo anti infiltrazione. Elevata resistenza meccanica ed agli agenti chimici. Disponibile in 4 colori.

Disponibile versione bicolore con vasca di colore grigio e coperchi in 3 colori differenti.

*Four-wheeled 770 liter mobile waste bin for differential refuse collection with flat lid. Product made of 100% recyclable HDPE (high density polyethylene), UV stabilized for outdoor use. Max load capacity 360 kg. Prepared for DIN standard frontal socket, equipped with four 200 mm diameter rubber caster wheels (two of them with braking system). Easy handling, ergonomic handles, rounded corners and edges. Equipped with ergonomic handles for handling, cap on the bottom for proper cleaning and sanitization. Flat lid with book opening and lip handle and anti-infiltration edge, seat for microchip housing. High mechanical and chemical resistance.*

*Available in 4 colors.*

*Bicolor available with grey body and lid in 3 different colors.*



**1/770/5**  
770 litri

●  
GRIGIO BIDONE  
(GRB)

●  
GIALLO  
(GIA)

●  
VERDE BIDONE  
(VEB)

●  
BLU BIDONE  
(BLB)



PRODOTTI IN  
MATERIALE  
RICICLABILE



A	778
B	1365
C	1243
D	1370
E	1270
F	1200
G	836
PESO / WEIGHT	43 Kg

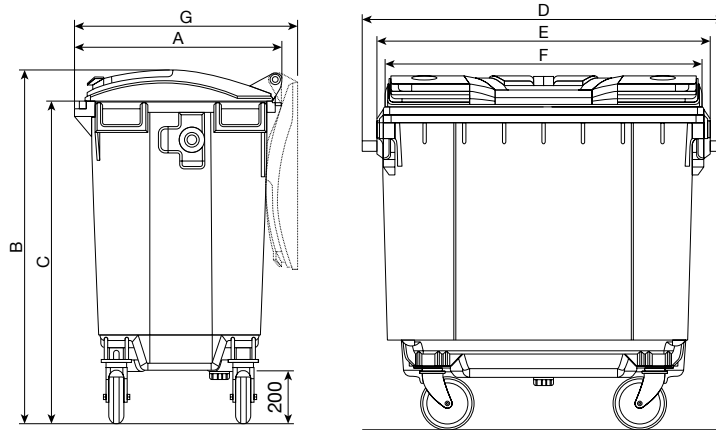

**7704**

Kit pedale per cassonetto 770 l  
770 l bin pedal



**1/770/5**  
770 litri

  
GRIGIO-GIALLO  
(GRB-GIA)

  
GRIGIO-VERDE  
(GRB-VEB)

  
GRIGIO-BLU  
(GRB-BLB)



PRODOTTI IN  
MATERIALE  
RICICLABILE

# CASSONETTI 4 RUOTE 1100 l

# CASSONETTI 4 RUOTE BICOLORE 1100 l

## PULIZIA & RACCOLTA DIFFERENZIATA

Cleaning & waste  
collection



TÜV Rheinland®

UNI EN 840  
Certificato  
Certified

**Cassonetto carrellato 4 ruote capacità 1100 litri con coperchio piano.**

Prodotto realizzato in HDPE (polietilene alta densità) 100% riciclabile stabilizzato UV per utilizzo in ambienti esterni.

Capacità di carico max 510 kg. Predisposto per presa frontale a pettine a norma DIN, dotato di quattro ruote girevoli (due delle quali con freno) con battistrada in gomma diametro 200. Grande maneggevolezza, assenza di bordi taglienti e spigoli smussati. Dotato di maniglie ergonomiche per la movimentazione, tappo sul fondo per una corretta pulizia e sanificazione. Coperchio piano con apertura a libro ed impugnatura a labbro e bordo anti infiltrazione. Elevata resistenza meccanica ed agli agenti chimici.

Disponibile in 4 colori.

Disponibile versione bicolor con vasca di colore grigio e coperchi in 3 colori differenti.

*Four-wheeled 1100 liter mobile waste bin for differential refuse collection with flat lid. Product made of 100% recyclable HDPE (high density polyethylene), UV stabilized for outdoor use. Max load capacity 510 kg. Prepared for DIN standard frontal socket, equipped with four 200 mm diameter rubber caster wheels (two of them with braking system). Easy handling, ergonomic handles, rounded corners and edges. Equipped with ergonomic handles for handling, cap on the bottom for proper cleaning and sanitization. Flat lid with book opening and lip handle and anti-infiltration edge, seat for microchip housing. High mechanical and chemical resistance.*

Available in 4 colors.

Bicolor available with grey body and lid in 3 different colors.



**1/1100/5**  
**1100 litri**

●  
GRIGIO BIDONE  
(GRB)

●  
GIALLO  
(GIA)

●  
VERDE BIDONE  
(VEB)

●  
BLU BIDONE  
(BLB)



PRODOTTI IN  
MATERIALE  
RICICLABILE



A	1070
B	1344
C	1280
D	1370
E	1270
F	1200
G	1127
PESO / WEIGHT	50 Kg

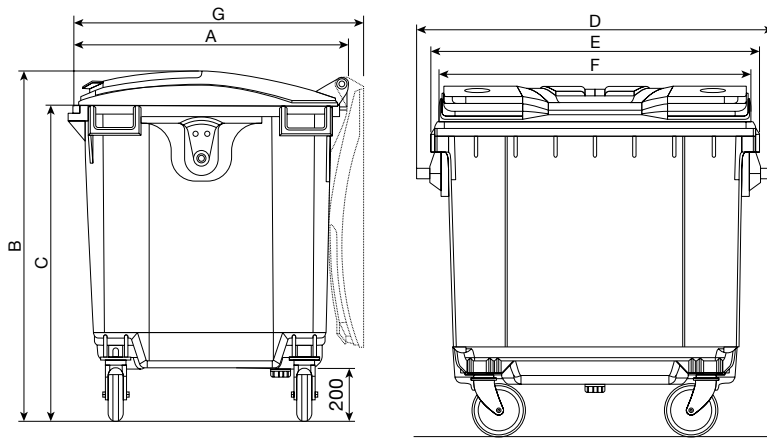

**11004**

Kit pedale per cassonetto 1100 l

1100 l bin pedal



**1/1100/5**  
1100 litri

  
GRIGIO-GIALLO  
(GRB-GIA)

  
GRIGIO-VERDE  
(GRB-VEB)

  
GRIGIO-BLU  
(GRB-BLB)



PRODOTTI IN  
MATERIALE  
RICICLABILE



# PORTARIFIUTI ECOLOGY

25/35 l

## PULIZIA & RACCOLTA DIFFERENZIATA

Cleaning & waste collection

Pratico e robusto contenitore portarifiuti, ideale per la raccolta differenziata urbana e domestica si adatta a tutti gli ambienti per il suo design moderno e funzionale, dotato di sportello basculante a becco e coperchio con meccanismo antirandagismo e comodo maniglione ergonomico con blocco verticale. Realizzato in compound di Polipropilene (PP) riciclabile al 100%, resistente agli agenti atmosferici, chimici ai raggi UV per utilizzo intensivo all'esterno. Totale assenza di spigoli, superfici lisce per una agevole pulizia e sanificazione, impilabile e inseribile, predisposizione per RFID, presa sul fondo per un facile svuotamento, coperchio con cerniere rinforzate per una apertura a 270°. Disponibile nelle misure da 25 lt e 35 lt., con contenitore e coperchio di colore Grigio e con sportello e maniglione di presa in 4 varianti di colore.

*Sturdy and functional waste bin, ideal for urban and domestic use. Its stylish and functional design makes it perfect for all environments. This bin is provided with a hinged and anti stray lid, ergonomic handle with vertical locking. The bin is made from polypropylene compound, 100% recyclable, weather, chemical and UV resistant allowing it to be safely used outside. No edges, smooth surfaces, easy to clean and disinfect, stackable and nestable, RFID technology predisposed. Reinforced hinges to allow a 270° opening, easy emptying system thanks to ergonomic grips on the bottom. Available sizes 25 and 35 l, grey bin with flap and handle in 4 colors.*



ECOLOGY 25	lt 25
A	370
B	370
C	410
PESO/WEIGHT	1,3 Kg

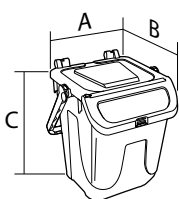

ECOLOGY 35	lt 35
A	370
B	370
C	520
PESO/WEIGHT	1,5 Kg

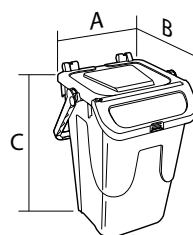

GRIGIO-BLU  
(GRB-BLB)



GRIGIO-BRUNO  
(GRB-BRB)



GRIGIO-GIALLO  
(GRB-GIA)



GRIGIO-VERDE  
(GRB-VES)



PRODOTTI IN  
MATERIALE  
RICICLABILE



# plastica

## seconda vita

### MIX ECO

Impilabile e inseribile.  
 Presa sul fondo per un facile svuotamento, coperchio con cerniere rinforzate per una apertura a 270°.  
 Dotato di sportello basculante a becco e coperchio con meccanismo antirandagismo e maniglione con blocco verticale.

Stackable and nestable.  
 Easy emptying system thanks to ergonomic grips on the bottom, reinforced hinges to allow a 270° opening.  
 Provided with a hinged and anti stray lid, ergonomic handle with vertical locking.



GRIGIO-BLU  
(GRB-BLB)



GRIGIO-BRUNO  
(GRB-BRB)



GRIGIO-GIALLO  
(GRB-GIA)



GRIGIO-VERDE  
(GRB-VES)



PRODOTTI IN  
 MATERIALE  
 RICICLABILE

## PULIZIA & RACCOLTA DIFFERENZIATA

Cleaning & waste collection

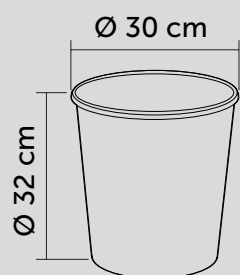

### Cestino gettacarta

Waste-paper basket



●  
GRIGIO  
(GRI)



●  
107/30  
NERO  
(NER)



●  
BRUNO BIDONE  
(BRR)



### Alzaimmondizia con manico

Standing dustpan

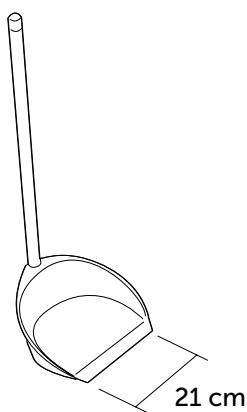

●  
BRUNO BIDONE  
(BRR)



### Paletta polvere

Dustpan

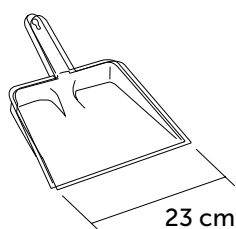

●  
BRUNO BIDONE  
(BRR)



PRODOTTI IN  
MATERIALE  
RICICLABILE

# BIDONI DUSTY

25 l



Pratico bidone portarifiuti da 25 litri, con coperchio dotato di chiusura a clip. Realizzato in polipropilene (PP) riciclabile 100%. Design moderno, si adatta a tutti gli ambienti. Disponibile con bidone di colore grigio e 4 varianti di colore per il coperchio utili per la raccolta differenziata.

*Practical 25 liter waste bin, with lid equipped with clip closures. Made of 100% recyclable polypropylene (PP). Modern design, adapts to all environments. Available with gray bin and 4 color variations for the lid useful for recycling.*

DUSTY	25 litri
A	400 mm
B	360 mm
C	450 mm
PESO / WEIGHT	0,95 Kg

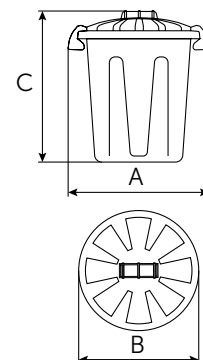

**plastica**  
seconda vita  
MIX ECO



**105/25**  
25 litri

●●  
GRIGIO-GIALLO  
(GRB-GIA)

●●  
GRIGIO-ROSSO  
(GRB-ROB)

●●  
GRIGIO-VERDE  
(GRB-VES)

●●  
GRIGIO-BLU  
(GRB-BLB)



PRODOTTI IN  
MATERIALE  
RICICLABILE

# BIDONI 80

80 l

## PULIZIA & RACCOLTA DIFFERENZIATA

Cleaning & waste  
collection



Pratico bidone portarifiuti da 80 litri con due ruote e coperchio ad apertura 120°.  
Design moderno e funzionale. Realizzato in copolimero di polipropilene (PP).

Adatto per utilizzi interni ed esterni. Leggero e di facile trasporto, resistente agli agenti atmosferici e chimici. Ideale per la raccolta differenziata. Totale assenza di spigoli vivi e con superfici lisce e di facile pulizia. Dotato di 4 ganci fissi fermasacchetto. Disponibile con fondo grigio e coperchi in 4 colori differenti oppure totalmente di colore bianco per utilizzi in ambienti specifici (HACCP, enti, ospedali ecc). Disponibile separatamente il kit pedale alzacoperchio.

*Two-wheeled serviceable 80 liter waste bin with 120° opening lid.*

*Modern and functional design. Made of 100% recyclable polypropylene (PP). Suitable for indoor and outdoor use. Light and easy to transport, resistant to atmospheric and chemical agents. Ideal for differential refuse collection. Total absence of sharp edges and with smooth and easy to clean surfaces. Equipped with 4 fixed hooks to lock the bag. Available with gray body and lids in 4 different colors or totally white for use in specific environments (HACCP, institutional offices, hospitals etc). Lid opener pedal kit available separately.*

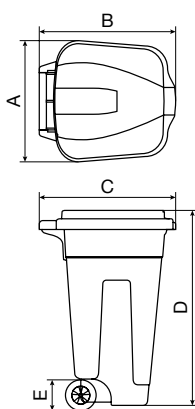

80	80 litri
A	450 mm
B	500 mm
C	500 mm
D	780 mm
E	120 mm
PESO / WEIGHT	3 Kg

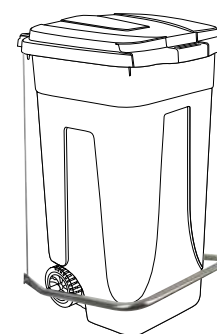

**804**  
Kit pedale  
Pedal kit



**80**  
80 litri



PRODOTTI IN  
MATERIALE  
RICICLABILE



Coperchi con chiusura a clip  
*Clip down lid*



Maniglia ergonomica e rinforzata  
per facilitarne il trasporto  
*Ergonomic and thicker handle for  
an easy handling*



Dotato di 4 ganci fermasacco  
*With 4 hooks keep bag*



Bidone facilmente impilabile  
con ruote montate  
*Easy stackable bins with  
preassembled wheels*



**804**  
Kit pedale optional  
*Pedal kit optional*

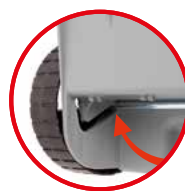

Ruote e assali premontati, meno errori e più facilità di spedizione  
con bloccaggio delle ruote per l'utilizzo finale  
*Wheels and axles already assembled, fast delivery and less  
problems. Wheels with brake for final use*



Alta scorrevolezza delle ruote  
antisdrucchiolo ed estrema  
maneggevolezza nello spostamento  
*No-slip wheels and easy to manoeuvre*



**95/80**  
Sacchetti immondizia per bidone  
raccolta differenziata 80 l  
*80 l bin liners bags*

**plastica**  
seconda vita  
MIX ECO

Tranne (BIL) / Except for (BIL)



GRIGIO-GIALLO  
(GRB-GIA)



GRIGIO-ROSSO  
(GRB-ROB)



GRIGIO-VERDE  
(GRB-VES)



GRIGIO-BLU  
(GRB-BLB)



BIANCO  
(BIL)

# BIDONI 100

100 l

## PULIZIA & RACCOLTA DIFFERENZIATA

Cleaning & waste  
collection

Pratico bidone portarifiuti da 100 litri con due ruote e coperchio ad apertura 270° e chiusura a clip. Design moderno e funzionale. Realizzato in copolimero di polipropilene (PP).

Adatto per utilizzi interni ed esterni. Leggero e di facile trasporto, resistente agli agenti atmosferici e chimici. Ideale per la raccolta differenziata. Totale assenza di spigoli vivi e con superfici lisce e di facile pulizia. Dotato di 4 ganci fissi fermasacchetto. Disponibile con fondo grigio e coperchi in 4 colori differenti.

*Two-wheeled serviceable 100 liter waste bin with 270° opening lid. Modern and functional design. Made of 100% recyclable polypropylene (PP). Suitable for indoor and outdoor use. Light and easy to transport, resistant to atmospheric and chemical agents. Ideal for differential refuse collection. Total absence of sharp edges and with smooth and easy to clean surfaces.*

*Equipped with 4 fixed hooks to lock the bag. Available with grey body and lids in 4 different colors.*

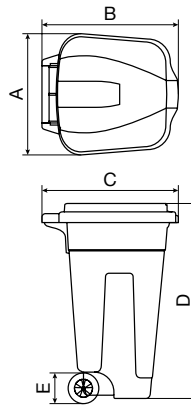

100	100 litri
A	490 mm
B	540 mm
C	540 mm
D	850 mm
E	143 mm
PESO / WEIGHT	3,70 Kg



100  
100 litri



PRODOTTI IN  
MATERIALE  
RICICLABILE



Coperchi con chiusura a clip  
*Clip down lid*



Maniglia ergonomica e rinforzata  
per facilitarne il trasporto  
*Ergonomic and thicker handle for  
an easy handling*



Dotato di 4 ganci fermasacco  
*With 4 hooks keep bag*



Bidone facilmente impilabile  
con ruote montate  
*Easy stackable bins with  
preassembled wheels*



Ruote e assali premontati, meno errori e più facilità di spedizione  
con bloccaggio delle ruote per l'utilizzo finale  
*Wheels and axles already assembled, fast delivery and less  
problems. Wheels with brake for final use*



Alta scorrevolezza delle ruote  
antisdrucchiolo ed estrema  
maneggevolezza nello spostamento  
*No-slip wheels and easy to manoeuvre*



**95/120**  
Sacchetti immondizia per bidone  
raccolta differenziata 120 l  
*120 l bin liners bags*

**plastica**  
seconda vita  
MIX ECO



GRIGIO-GIALLO  
(GRB-GIA)



GRIGIO-ROSSO  
(GRB-ROB)



GRIGIO-VERDE  
(GRB-VES)



GRIGIO-BLU  
(GRB-BLB)



# BIDONI 100 PUSH

100 l

## PULIZIA & RACCOLTA DIFFERENZIATA

Cleaning & waste collection

**plastica**  
seconda vita  
MIX ECO



Maniglia ergonomica e rinforzata per facilitarne il trasporto  
*Ergonomic and thicker handle for an easy handling*



Dotato di 4 ganci fermasacco  
*With 4 hooks keep bag*



Campana basculante per bidone Cento Push  
*Flap lid for bin Cento Push*



Bidone facilmente impilabile con ruote montate  
*Easy stackable bins with preassembled wheels*



Alta scorrevolezza delle ruote antiscivolo ed estrema maneggevolezza nello spostamento  
*No-slip wheels and easy to manoeuvre*



Ruote e assali premontati, meno errori e più facilità di spedizione con bloccaggio delle ruote per l'utilizzo finale  
*Wheels and axles already assembled, fast delivery and less problems. Wheels with brake for final use*

Pratico bidone portarifiuti da 100 litri con due ruote e coperchio a campana con pratica apertura basculante. Design moderno e funzionale. Realizzato in copolimero di polipropilene (PP). Adatto per utilizzi interni ed esterni. Leggero e di facile trasporto, resistente agli agenti atmosferici e chimici. Ideale per la raccolta differenziata. Totale assenza di spigoli vivi e con superfici lisce e di facile pulizia. Dotato di 4 ganci fissi fermasacco. Disponibile in colore grigio e sportellino basculante in 4 colori differenti.

*Two-wheeled serviceable 100 liter waste bin with bell-shaped lid and handy tilting opening. Modern and functional design. Made of 100% recyclable polypropylene (PP). Suitable for indoor and outdoor use. Light and easy to transport, resistant to atmospheric and chemical agents. Perfect for differential refuse collection. Total absence of sharp edges and with smooth and easy to clean surfaces. Equipped with 4 fixed hooks to lock the bag. Available with grey body and tilting window in 4 different colors.*

100 PUSH	100 litri
A	490 mm
B	540 mm
C	540 mm
D	950 mm
E	143 mm
PESO / WEIGHT	3,70 Kg

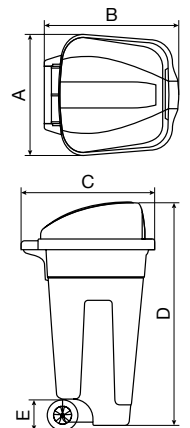

**100 PUSH**  
100 litri



**95/1**  
Sacchetti immondizia per bidone raccolta differenziata 100 l  
100 l bin liners bags



GRIGIO-GIALLO  
(GRB-GIA)



GRIGIO-ROSSO  
(GRB-ROB)



GRIGIO-VERDE  
(GRB-VES)



GRIGIO-BLU  
(GRB-BLB)



PRODOTTI IN  
MATERIALE  
RICICLABILE

# BIDONI NELLO

80 l



**Nello** è un bidone di nuova concezione che si distingue innanzitutto per il felice connubio estetico-funzionale evidenziato da linee morbide e ben raccordate tra loro. Dotato di ruote e comoda maniglia per spostamenti veloci e sicuri, pedale di apertura e anello reggisacco.

Si adatta agli ambienti di lavoro professionale e hobbistico, come officine, garage, laboratori industriali.

**151-GRN** completo di n.8 tappi in 4 colori per una corretta identificazione della differenziata.

*Nello is a new-concept bin, which combines beauty and functionality stressed by an elegant and harmonic design. Equipped with wheels and a handle for fast and safe movings, an opening pedal and bags holder ring. It is suitable for internal use in all locations (workshops, garages, studios). 151-GRN includes a set of nr 8 cups in 4 different colours for a right waste separation and identification.*

NELLO	80 litri
A	650 mm
B	810 mm
C	400 mm
PESO / WEIGHT	6,20 Kg

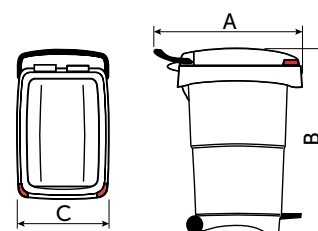

**151-GRN** N.8 tappi in 4 colori diversi.

**151-GRN** Set of nr 8 cups in 4 different colours.



**151**  
80 litri

**plastica**  
seconda vita  
MIX ECO

Tranne (BIL) / Except for (BIL)



**95/80**  
Sacchetti immondizia per bidone NELLO 80 l

Bin liners for NELLO 80 l



●  
GRIGIO  
(GRN)



○  
BIANCO  
(BIL)



Apertura a pedale  
Opening pedal



PRODOTTI IN  
MATERIALE  
RICICLABILE

# TRESPOLO

110 l

## PULIZIA & RACCOLTA DIFFERENZIATA

Cleaning & waste  
collection

Trespolo portasacco da 110 litri con anello.

Realizzato in HDPE (polietilene alta densità) 100% riciclabile. Economico, pratico e versatile, leggero e di semplice utilizzo particolarmente adatto per la raccolta differenziata per interni ed esterni. Disponibile nei colori verde o grigio scuro oppure nella versione bicolore con corpo grigio e coperchio in 4 colori differenti.

*Trestle bag holder 110 liter with locking bag ring. Made of 100% recyclable HDPE (high density polyethylene). Cheap, practical and adaptable, light and easy to use, particularly suitable for indoor and outdoor differential refuse collection. Available in green or dark gray color or in the bicolor version with grey body and lid in 4 different colors.*

A	380
B	850
C	510
PESO / WEIGHT	2,43 Kg

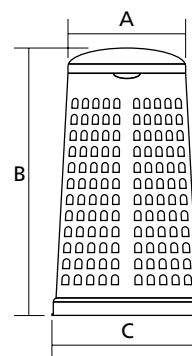



# plastica

seconda vita  
MIX ECO

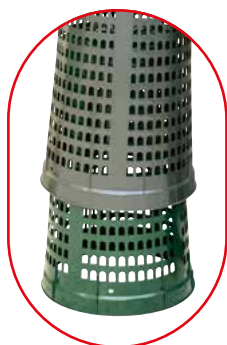

69/110  
110 litri



95/120

Sacchetti immondizia per TRESPOLO  
*Bin liners TRESPOLO waste bin*



PRODOTTI IN  
MATERIALE  
RICICLABILE

# ECO-AIR 4

## PULIZIA & RACCOLTA DIFFERENZIATA

Cleaning & waste  
collection



**100/4-GR**  
Completo di 4 secchi  
Complete with 4 buckets



### KIT 100/4-MIX

Ordinabile anche separatamente  
To be ordered also separately

**Mobiletto ventilato in lamiera elettrosaldata verniciato a forno in polvere epossidica a due ribalte sovrapposte contenenti due secchi da 20 l ognuna.**

**A - Aerazione, ventilazione:** il mobiletto è dotato di griglie di aerazione che hanno lo scopo di favorire la fermentazione dei residui organici e di smaltire l'odore sgradevole.

**B - Robusti piedi, sollevato da terra per una agevole pulizia.**

*Cabinet in electro welded plate painted by epoxy powder oven with two superposed tilt drawers including two 20 l buckets each.*

*A - Airing/ ventilation: the cabinet is equipped with grates that help fermentation of the organic refusal and discharge the unpleasant odours.*

*B - Strong feet, lifted base to allow an easy cleaning.*

A	100 cm
B	43 cm
C	65 cm
D	100 cm
E	25 cm
PESO / WEIGHT	21 Kg

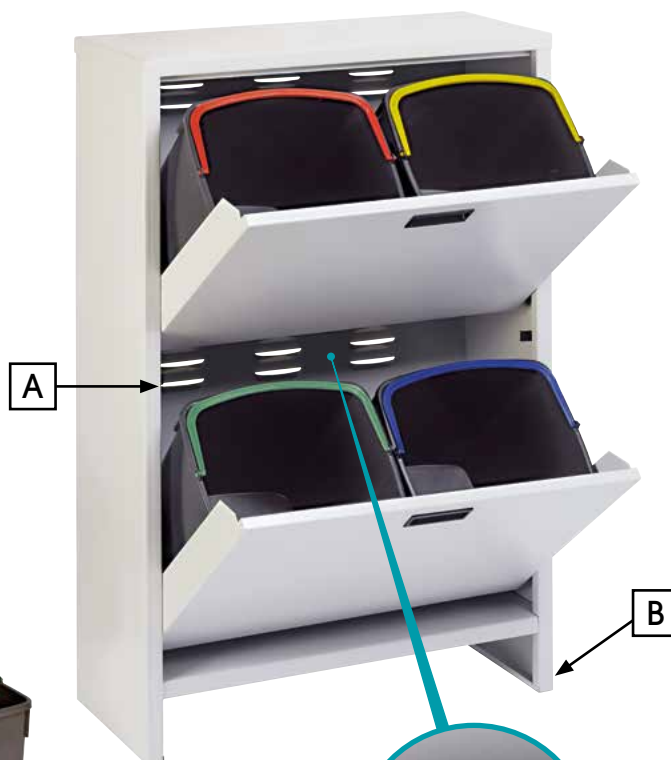
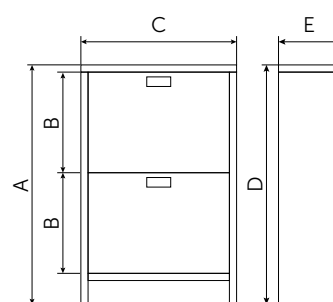

Aerazione,  
ventilazione  
Airing, ventilation

RAL 7035

# BIDONI 91

60 - 80 - 100 l



## Bidone con coperchio

*Bin with hinged lid*

art. 91	Ø	H	capacità
91/060	Ø 45 cm	H 60 cm	60 l
91/080	Ø 45 cm	H 74 cm	80 l
91/100	Ø 45 cm	H 88 cm	100 l

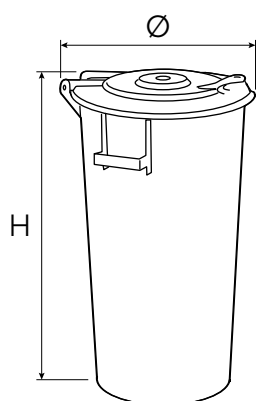

**95/1**

Sacchetti immondizia per bidone con cerniera.

*Bin liners for hinged bin.*



**91/060**  
60 litri



**91/080**  
80 litri



**91/100**  
100 litri

●  
NERO  
(NER)



PRODOTTI IN  
MATERIALE  
RICICLABILE

# BIDONI INDUSTRIALI NERI

da 35 a 200 l

## PULIZIA & RACCOLTA DIFFERENZIATA

Cleaning & waste collection



Art. 19/1

GRIGIO (GR)

Carrello per bidone industriale 75-100 l  
A seconda del lato in cui vengono montate le ruote è adatto al trasporto di bidoni da 75 litri o da 100 litri.

75-100 l Industrial bin trolley  
You can fit the wheels in both sizes, one size is suitable for the 75 litres industrial bin and one for the 100 litres bin.



art.	Capacità Capacity	h	Ø
8/0035	35 l.	41	39
8/0050	50 l.	47	46
8/0075	75 l.	57	48
8/0100	100 l.	67	52
8/0150	150 l.	71	62
8/0200	200 l.	81	67

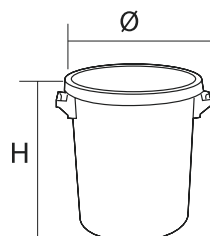

8/0035



8/0050



8/0075



PP 77/035



PP 77/050



PP 77/075



8/0100



8/0150



8/0200



PP 77/100



77/150



77/200

NERO (NER)



PRODOTTI IN MATERIALE RICICLABILE



PRODOTTI IN MATERIALE RICICLABILE

# BIDONI INDUSTRIALI VERDI

da 35 a 300 l



art.	Capacità Capacity	h	Ø
92/035	35 l.	41	39
92/050	50 l.	47	46
92/075	75 l.	57	48
92/100	100 l.	67	52
92/150	150 l.	71	62
92/200	200 l.	81	67
92/300	300 l.	89	76

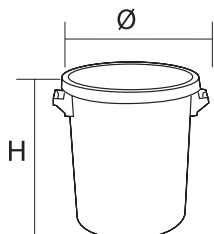

92/035



PP 27/035



92/050



PP 27/050



92/075



PP 27/075



92/100



PP 27/100



92/150



27/150



92/200



27/200



92/300



27/300

●  
VERDE INDUSTRIALE  
(VEI)



PRODOTTI IN  
MATERIALE  
RICICLABILE



PRODOTTI IN  
MATERIALE  
RICICLABILE





**CASSE**



**MASTELLI CANTINA**



**BIDONI CANTINA**



# ENOLOGIA & AGRICOLTURA

Enology & Agriculture



**ALTRO ENOLOGIA**



**MASTELLI  
AGRICOLTURA**



**INNAFFIATOI**

# CASSE

inseribili e sovrapponibili

## ENOLOGIA & AGRICOLTURA

Enology & Agriculture

art.	L	H	P	Capacità Capacity
131/50	55	31	43	50 l
131/65	63	34	44	65 l
133/50	57	3	43	-
133/65	65	3	45	-

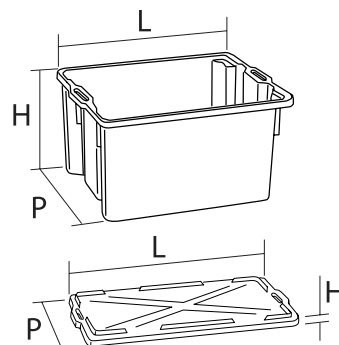

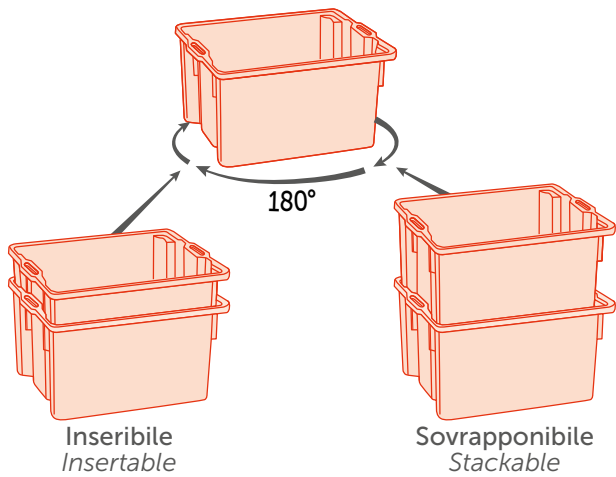

131/50



131/65



133/50 - 133/65  
COPERCHIO PER CASSA  
CRATE LID



PRODOTTI IN  
MATERIALE  
RICICLABILE

# MASTELLI CANTINA

**ENOLOGIA &  
AGRICOLTURA**  
Enology & Agriculture

art.	H	Ø	Capacità Capacity	
2/0110	30	80	110 l	sottotino
2/0275	35	110	275 l	sottotino
2/0225	54	86	225 l	
2/0350	71	95	350 l	
2/0500	82	104	500 l	
2/0700	90	115	700 l	
2/1000	95	134	1000 l	

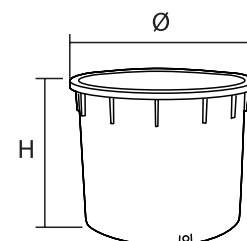

**17**

**Filtro svinarola per  
rubinetto 1"**

*Wine filter 1" tap*



**20/ 1**

**Rubinetto 1"**

*Tap 1"*



**150**

**Maniglia per  
mastello**

*Handle tub*





**2/0110**



**2/0275**



**2/0225**



**2/0350**



**2/0500**



**2/0700**



**2/1000**



**32/500**



**32/700**



PRODOTTI IN  
MATERIALE  
RICICLABILE

# BIDONI CANTINA

**ENOLOGIA &  
AGRICOLTURA**  
Enology & Agriculture

art.	Capacità Capacity	H	Ø
13/150	150 l	71	62
13/200	200 l	81	67
13/300	300 l	89	76

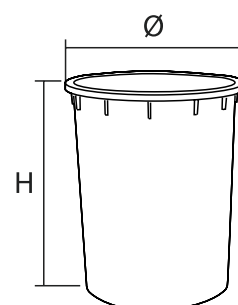

**20/3/4**

**Rubinetto 3/ 4"**

*Tap 3/ 4"*





**13/150**



**13/200**



**13/300**



**32/150**



**32/200**



**32/300**



PRODOTTI IN  
MATERIALE  
RICICLABILE



## ENOLOGIA & AGRICOLTURA

Enology & Agriculture



## CESTO TONDO con manico

### ART. 53

Cesto tondo con  
manico in plastica - 15 l

*Round basket with  
plastic handle - 15 l*

### ART. 53/F

Cesto tondo con  
manico in ferro - 15 l

*Round basket with  
iron handle - 15 l*



53

ARAGOSTA (ARA)



PRODOTTI IN  
MATERIALE  
RICICLABILE

## CESTO OVALE con manico

### ART. 74

Cesto ovale con  
manico in plastica - 20 l

*Oval basket with  
plastic handle - 20 l*

### ART. 74/F

Cesto ovale con  
manico in ferro - 20 l

*Oval basket with  
iron handle - 20 l*



74

ARAGOSTA (ARA)



PRODOTTI IN  
MATERIALE  
RICICLABILE

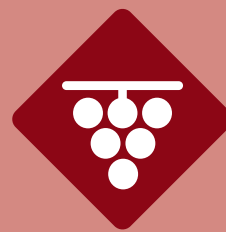

# MASTELLO

2 manici

art.	H	Ø	Capacità Capacity
126	45	49	50 l

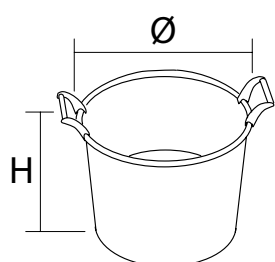

ARAGOSTA (ARA)

126



PRODOTTI IN  
MATERIALE  
RICICLABILE

# TIRA OLIO

Art. 63

Tira olio - 0,5 l

Oil-trap - 0,5 l



63



NEUTRO (N)



PRODOTTI IN  
MATERIALE  
RICICLABILE

**ENOLOGIA &  
AGRICOLTURA**  
Enology & Agriculture



## CANTINETTA 6 posti

SOVRAPPONIBILE

*Six bottle holder*



67



BRUNO RAME (BRR)



PRODOTTI IN  
MATERIALE  
RICICLABILE

## CESTELLO PORTA BOTTIGLIE 6 posti

*Stackable six  
bottle crate*



23



ROSSO (ROM)



VERDE (VET)



PRODOTTI IN  
MATERIALE  
RICICLABILE

## CESTELLO PORTA BOTTIGLIONI 4 posti

*Stackable four  
bottle crate*



24



ROSSO (ROM)



VERDE (VET)



PRODOTTI IN  
MATERIALE  
RICICLABILE

# MASTELLI AGRICOLTURA

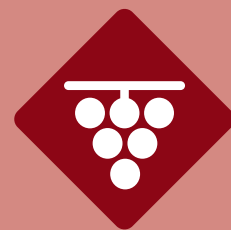

art.	H	Ø	Capacità Capacity
8/0110	30	80	110 l
8/0225	54	86	225 l
8/0350	71	95	350 l
8/0500	82	104	500 l
8/0700	90	115	700 l
8/1000	95	134	1000 l

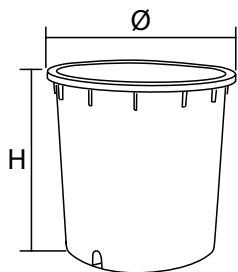

**17**

Filtro svinarola per rubinetto 1"

Wine filter 1" tap



**20/ 1**

Rubinetto 1"

Tap 1"



**150**

Maniglia per mastello

Handle tub



**8/0110**



**8/0225**



**8/0350**



**8/0500**



**8/0700**



**8/1000**



**77/500**



**77/700**

NERO (NER)



PRODOTTI IN  
MATERIALE  
RICICLABILE

# INNAFFIATOI

## ENOLOGIA & AGRICOLTURA

Enology & Agriculture

Gamma di innaffiatoi estremamente robusti e dal design tradizionale, con riserva d'acqua e comoda impugnatura.

*Range of extremely robust watering cans with a traditional design, water reserve and comfortable handle.*

art.	Capacità Capacity
87/02	2 l
87/04	4 l
87/08	8 l
87/12	12 l
87/16	16 l



87/02



ROSSO  
(ROM)

VERDE  
(VET)



87/04



87/08



87/12



87/16



Diffusore a doccia  
incluso nei modelli:  
4 - 8 - 12 - 16



PRODOTTI IN  
MATERIALE  
RICICLABILE



112



**TANICHE**

114



**TANICHE  
BENZINA**

115



**FUSTINI A  
BOTTICELLA**

116



**BIDONI COLLO  
LARGO**

117



**BIDONI  
INDUSTRIALI**

120



**CASSE  
ALIMENTARI**

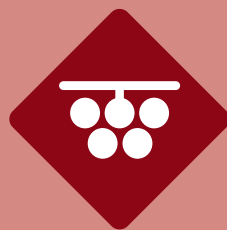

# TRASPORTO LIQUIDI & INDUSTRIA ALIMENTARE

Liquid transport & food industry



**MASTELLI**



**IMBUTI**



**SECCHI INDUSTRIALI**



**CARAFFE**



**SESSOLE**



## TRASPORTO LIQUIDI & INDUSTRIA ALIMENTARE

Liquid transport  
& food industry



## Tanica due usi *Tank double use*



61

## Tanica con rubinetto *Tank with tap*

art.	Capacità Capacity
73/10	10 l
73/20	20 l
61	15 - 3,5 l



73/10



73/20



art.	Capacità Capacity
125/01	1 l
125/02	2 l
125/03	3 l
125/05	5 l
*125/10	10 l
*125/15	15 l
*125/20	20 l
*125/25	25 l
*125/30	30 l



125/01



125/02



125/03



\* **Versatore telescopico incluso**  
 \* *Telescopic pourer included*



125/05



125/10



125/15



125/20



125/25



125/30



PRODOTTI IN  
 MATERIALE  
 RICICLABILE

# TANICHE BENZINA

**TRASPORTO  
LIQUIDI &  
INDUSTRIA  
ALIMENTARE**  
Liquid transport  
& food industry

Taniche per combustibili liquidi in polietilene alta densità rinforzato. Dotate di travasatore flessibile avvitabile. Tappo di chiusura ermetico con anello di sicurezza. Omologazione UN a norma direttive CEE. Con indicatore di livello

*Jerry can for liquid fuel in reinforced high density polyethylene. Provided with flexible screw pouring spout. Sealed cap with safety ring. All size are of UN approved standard and specification. With level indicator*

art.	Capacità Capacity
115/05	5 l
115/10	10 l



115/05



115/10

**Indicatore di livello**

*V-stripe*



**Beccuccio flessibile**

*Pouring spout*



VERDE SCURO (VES)



PRODOTTI IN  
MATERIALE  
RICICLABILE

# FUSTINI A BOTTICELLA



art.	Capacità Capacity	h	Ø A	Ø B
97/005	5 l	28	18	8,5
97/010	10 l	32	23	9,5
97/015	15 l	37	27	9,5
97/020	20 l	41	29	9,5
97/025	25 l	44	32	9,5
97/050	50 l	56	39	11,0
97/100	100 l	71	49	11,0

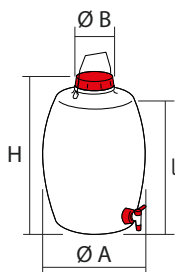

## ACCESSORI ACCESSORIES



**20/1/4**  
**Rubinetto 1/4"** (PP)   
**Tap 1/4"**

## PARTICOLARE



**97/005**



**97/010**



**97/015**



**97/020**



**97/025**



**97/050**



**97/100**

○  
NEUTRO (N)



PRODOTTI IN  
MATERIALE  
RICICLABILE

# BIDONI COLLO LARGO

## TRASPORTO LIQUIDI & INDUSTRIA ALIMENTARE

Liquid transport  
& food industry



art.	Capacità Capacity	H	Ø A	Ø B
78/02	2 l	21	14	10
78/05	5 l	31	16	10
78/10	10 l	35,5	21,5	11

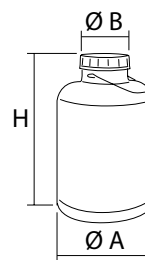

**78/02**



**78/05**



**78/10**



NEUTRO (N)



PRODOTTI IN  
MATERIALE  
RICICLABILE

# BIDONI INDUSTRIALI

con chiusura ad anello



Contenitore con chiusura ad anello in metallo completo di guarnizione.  
Articolo non a tenuta stagna

*Metal ring closure bin complete of gasket. Not leak-proof.*

art.	Capacità Capacity	H	Ø
18/075	75 l	57	48
18/100	100 l	67	52

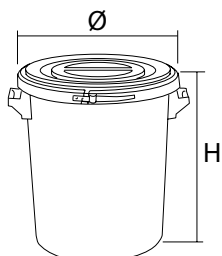

18/075



18/100



19/01

GRIGIO (GR)

## Art. 19/1

Carrello per bidone industriale 75-100 l. A seconda del lato in cui vengono montate le ruote è adatto al trasporto di bidoni da 75 litri o da 100 litri.

*75-100 l Industrial bin trolley. You can fit the wheels in both sizes, one size is suitable for the 75 litres industrial bin and one for the 100 litres bin.*

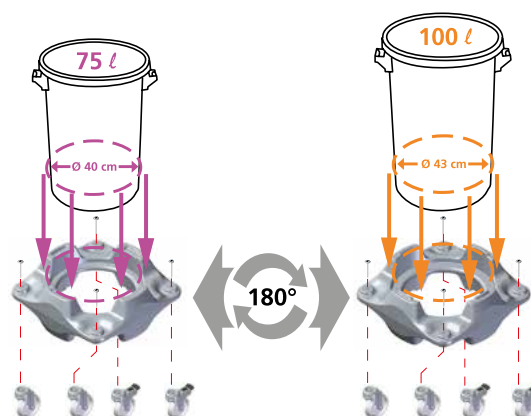

NEUTRO (N)



PRODOTTI IN  
MATERIALE  
RICICLABILE

# BIDONI INDUSTRIALI

da 35 a 300 l

## TRASPORTO LIQUIDI & INDUSTRIA ALIMENTARE

Liquid transport  
& food industry

art.	Capacità Capacity	H	Ø
19/035	35 l	41	39
19/050	50 l	47	46
19/075	75 l	57	48
19/100	100 l	67	52
19/150	150 l	71	62
19/200	200 l	81	67
19/300	300 l	89	76

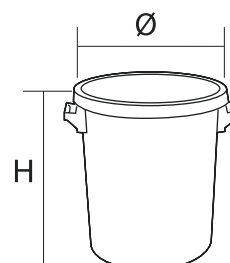

**19/01**

●  
GRIGIO (GR)

### Art. 19/1

Carrello per bidone industriale 75-100 l

A seconda del lato in cui vengono montate le ruote è adatto al trasporto di bidoni da 75 litri o da 100 litri.

*75-100 l. Industrial bin trolley*

*You can fit the wheels in both sizes, one size is suitable for the 75 litres industrial bin and one for the 100 litres bin.*

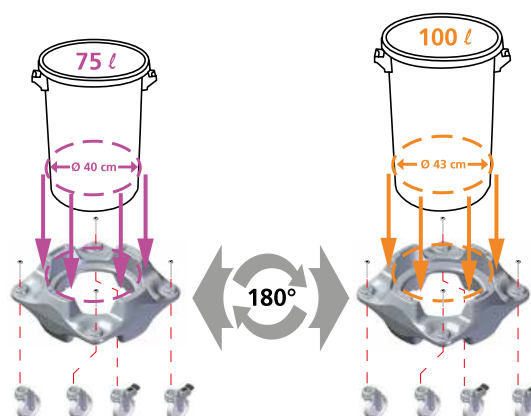



**19/035**



**19/050**



**19/075**



**19/100**



**PP 59/035**



**PP 59/050**



**PP 59/075**



**PP 59/100**



**19/150**



**19/200**



**19/300**



**59/150**



**59/200**



**59/300**

○  
NEUTRO (N)



PRODOTTI IN  
MATERIALE  
RICICLABILE



PRODOTTI IN  
MATERIALE  
RICICLABILE



# CASSE

inseribili e sovrapponibili

## TRASPORTO LIQUIDI & INDUSTRIA ALIMENTARE

Liquid transport  
& food industry

art.	L	H	P	Capacità Capacity
131/50	55	31	43	50 l
131/65	63	34	44	65 l
131/90	72	36	47	90 l
132/50	55	31	43	50 l
132/65	63	34	44	65 l
133/50	57	3	43	-
133/65	65	3	45	-
133/90	75	3,5	47	-

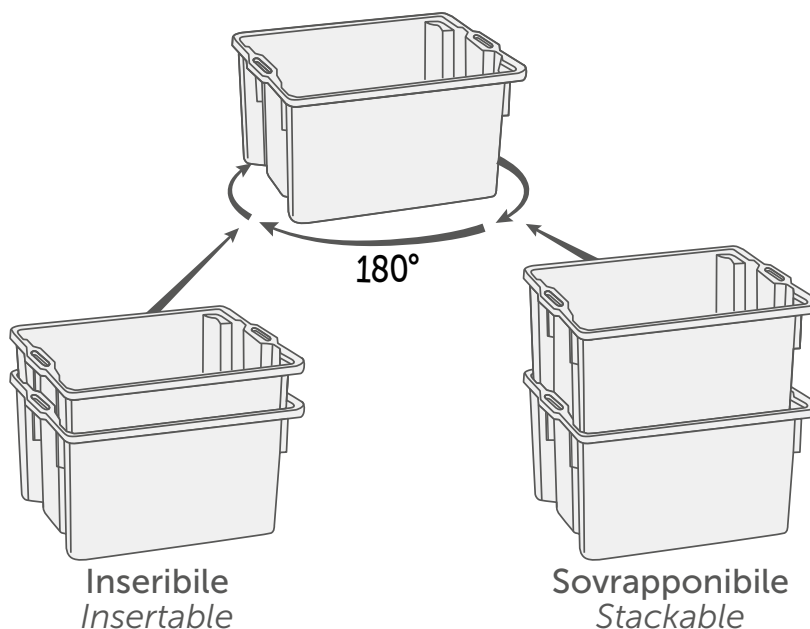
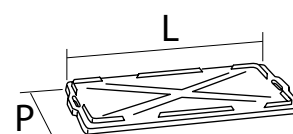
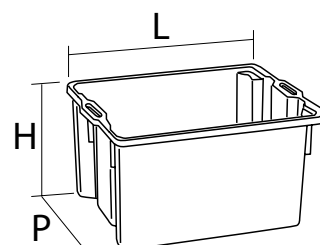



131/50

131/65

131/90



132/50



132/65



**133/50 - 133/65 - 133/90**  
Coperchio per casse 131 - 132  
*Lid for crates 131 - 132*



PRODOTTI IN  
MATERIALE  
RICICLABILE

# CASSE ALIMENTARI

## FOOD BOX

### TRASPORTO LIQUIDI & INDUSTRIA ALIMENTARE

Liquid transport  
& food industry

art.	L	H	P	Capacità Capacity
143/20	38	30	28	20 l
143/40	58	26	38	40 l
143/60	58	38	38	60 l

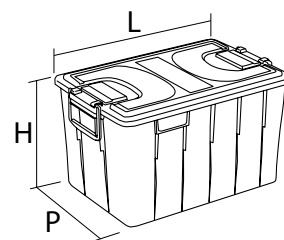

Casse grandi e piccole tra loro sovrapponibili per facilitarne il trasporto, coperchio in dotazione con chiusura

*Large and small crate can be put one on the other to facilitate transport, cover with enclosed closures*



Porta targhetta  
Tag holder



143/20



143/40



143/60

○ BIANCO (BIM)      ○ TRASPARENTE (TS)



PRODOTTI IN  
MATERIALE  
RICICLABILE

# CASSE ALIMENTARI

## LIGHT BOX



art.	L x P x H Esterne External	L x P x H Interne Internal	Capacità Capacity
5900	655 x 435 x 30	-	-
5908	650 x 425 x 85	600 x 400 x 80	19 l
5911	650 x 425 x 115	600 x 400 x 110	25 l

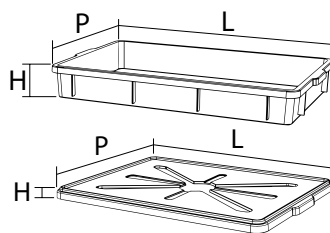

impilabili



temperatura  
esercizio



**5900**



**5908**



**5911**



BIANCO (BIM)



PRODOTTI IN  
MATERIALE  
RICICLABILE

# CASSE ALIMENTARI

400x300

## TRASPORTO LIQUIDI & INDUSTRIA ALIMENTARE

Liquid transport  
& food industry

art.	L	P	H
2210-N	400	300	10
2213-N	400	300	13
2217-N	400	300	17
2222-N	400	300	22
2232-N	400	300	32
2200-N	400	300	–
2200C-N	400	300	–

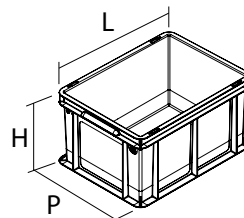

impilabili



temperatura  
esercizio



ESEMPIO DI COMPONIBILITÀ  
MODULARITY EXAMPLE



CASSA ALIMENTARE 400x300  
MANIGLIE INTEGRATE  
EURONORM CRATE 400x300  
INTEGRATED HANDLES



CASSA ALIMENTARE 400x300  
PREDISPOSTA PER CHIUSURA E  
SIGILLO GARANZIA  
EURONORM 400x300 CRATE  
DESIGNED FOR CLOSURE AND  
GUARANTEE SEAL



CASSA ALIMENTARE 400x300  
PREDISPOSTA PER CHIUSURA  
EURONORM CRATE 400x300  
DESIGNED FOR LOCKING



**2210-N**



**2213-N**



**2217-N**



**2222-N**



**2232-N**



**2200-N**

**COPERCHIO PER CASSA 400X300**  
*LID FOR 400x300 CRATE*



**2200C-N**

**COPERCHIO PER CASSA 400X300**  
**CON CHIUSURA**  
*LID FOR 400x300 CRATE WITH LOCKING*



PRODOTTI IN  
MATERIALE  
RICICLABILE

# CASSE ALIMENTARI

600x400

TRASPORTO  
LIQUIDI &  
INDUSTRIA  
ALIMENTARE

Liquid transport  
& food industry

art.	L	P	H
4407-N	600	400	7
4410-N	600	400	10
4413-N	600	400	13
4417-N	600	400	17
4422-N	600	400	22
4432-N	600	400	32
4400-N	600	400	—

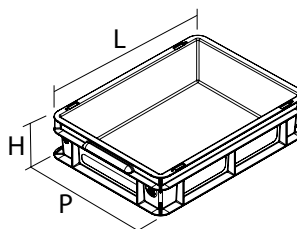

impilabili



temperatura  
esercizio



**4400-N**

COPERCHIO PER CASSA 60X40  
LID FOR 600x400 CRATE



**4407-N**



**4410-N**



**4413-N**



**4417-N**



**4422-N**



**4432-N**



NEUTRO (N)



PRODOTTI IN  
MATERIALE  
RICICLABILE



# CASSE FORATE

## 600x400



art.	L	P	H
6007-N	600	400	7
6010-N	600	400	10
6013-N	600	400	13

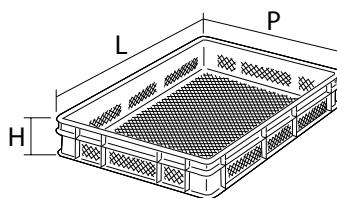

**6007**



**6010**



**6013**



NEUTRO (N)



PRODOTTI IN  
MATERIALE  
RICICLABILE

art.	L	P	H
5800	62	42	14

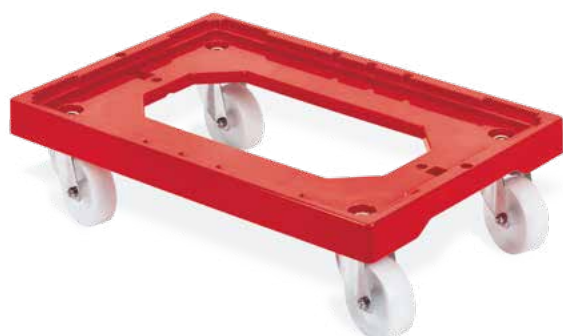
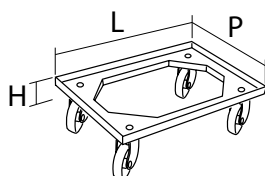

**5800**

Carrello per cassetta 600x400  
*Trolley 600x400 for crates*



max.  
250 Kg



ROSSO (ROB)



PRODOTTI IN  
MATERIALE  
RICICLABILE





# MASTELLI

## TRASPORTO LIQUIDI & INDUSTRIA ALIMENTARE

Liquid transport  
& food industry

art.	H	Ø	Capacità Capacity	
7/0110	30	80	110 l	sottotino
7/0275	35	110	275 l	sottotino
7/0225	54	86	225 l	
7/0350	71	95	350 l	
7/0500	82	104	500 l	
7/0700	90	115	700 l	
7/1000	95	134	1000 l	

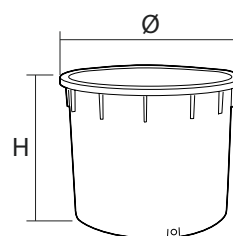

**17**

Filtro svinarola per  
rubinetto 1"

*Wine filter 1" tap*



**20/ 1**

Rubinetto 1"

*Tap 1"*



**150**

Maniglia per  
mastello

*Handle tub*





**7/0110**



**7/0275**



**7/0225**



**7/0350**



**7/0500**



**7/0700**



**7/1000**



**59/500**



**59/700**



PRODOTTI IN  
MATERIALE  
RICICLABILE

TRASPORTO  
LIQUIDI &  
INDUSTRIA  
ALIMENTARE

Liquid transport  
& food industry



## Colalatte con filtro

*Mix colander with stainer*



**35**  
Ø 27 cm.

○  
BIANCO (BIM)

## Imbuto con tubo flessibile e filtro

*Funnel with flexible tube and filter*



**10/26**  
Ø 26 cm.

○  
BIANCO (BIM)



PRODOTTI IN  
MATERIALE  
RICICLABILE



## Imbuto

*Funnel*



54

Ø 6 - 8 - 10 - 12 - 14 - 16 - 18 - 20 - 22 - 24 - 26 - 30 cm.



BIANCO (BIM)

## Imbuto con porta filtro

*Funnel with filter-support*



43

Ø 22 - 26 - 30 - 35 cm.



**ART. 147/10**  
Filtro Ø 10 cm.  
per imbuto Ø 22 cm.  
Filter Ø 10 cm.  
for funnel Ø 22 cm.



**ART. 147/12**  
Filtro Ø 12 cm.  
per imbuto Ø 26 - 30 - 35 cm.  
Filter Ø 12 cm.  
for funnel Ø 26 - 30 - 35 cm.



BIANCO (BIM)



PRODOTTI IN  
MATERIALE  
RICICLABILE

# SECCHI INDUSTRIALI

TRASPORTO  
LIQUIDI &  
INDUSTRIA  
ALIMENTARE

Liquid transport  
& food industry

## Secchi industriali graduati

*Graduated industrial bucket*

art.	Capacità Capacity
65/12	12 l
65/15	15 l
65/18	18 l

65GRI	●	—
65 N	○	



65/12



65/15



65/18

○ NEUTRO (N)      ● GRIGIO (GRI)



PRODOTTI IN  
MATERIALE  
RICICLABILE



## Caraffe graduate

### Graduated jug

art.	Capacità Capacity
6/0500	0,5 l
6/1000	1 l
6/2000	2 l
6/3000	3 l
6/5000	5 l



**6/0500**



**6/1000**



**6/2000**



**6/3000**



**6/5000**

○  
BIANCO (BIM)

○  
TRASPARENTE (TS)



PRODOTTI IN  
MATERIALE  
RICICLABILE

TRASPORTO  
LIQUIDI &  
INDUSTRIA  
ALIMENTARE

Liquid transport  
& food industry



## Sessole rettangolari

*Rectangilars large-spoon*

art.	cm.
136/19	19
136/24	24
136/29	29
136/34	34
136/38	38
136/42	42
31	43



**31**

○  
BIANCO (BIM)



PRODOTTI IN  
MATERIALE  
RICICLABILE



# Sessole tonde

*Rounds spoon*



**136/19**



**136/24**



**136/29**



**136/34**



**136/38**



**136/42**



BIANCO (BIM)



PRODOTTI IN  
MATERIALE  
RICICLABILE





138



**BAGNI QUADRI**

139



**CATINI**

140



**BAGNI TONDI**

141



**BAGNI OVALI**

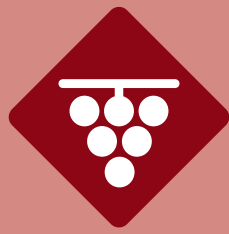

# CASALINGHI

## Household



**MASTELLI  
3 MANICI**



**SECCHI**



**SCOLAPASTA**



**INSALATIERE**

# BAGNI QUADRI

## SQUARE BASIN

CASALINGHI

Household

art.	L	H	P	Capacità Capacity
21/30	30	15	30	13 l
21/32	32	15	32	15 l
21/34	34	17	34	19 l

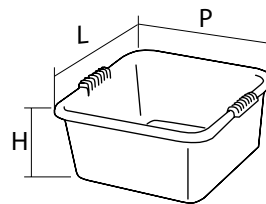

21/30



21/32



21/34

21AZP	●	—
21 N	○	🍴

○  
NEUTRO (N)

●  
AZZURRO (AZP)



PRODOTTI IN  
MATERIALE  
RICICLABILE

# CATINI

## Basin



art.	Ø	art.	Ø
52/24	24	52/32	32
52/26	26	52/34	34
52/28	28	52/36	36
52/30	30	52/38	38

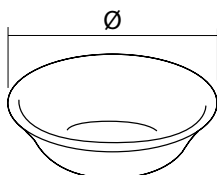

**52/24**



**52/26**



**52/28**



**52/30**



**52/32**



**52/34**



**52/36**



**52/38**

○  
BIANCO (BIM)



PRODOTTI IN  
MATERIALE  
RICICLABILE

# BAGNI TONDI

Round basin

**CASALINGHI**  
Household

art.	Ø	Capacità Capacity	art.	Ø	Capacità Capacity
41/32	32	7 l	41/40	40	14 l
41/34	34	8 l	41/45	45	20 l
41/36	36	11 l	41/50	50	30 l

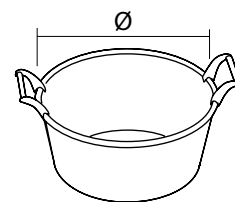

**41/32**



**41/34**



**41/36**



**41/40**



**41/45**



**41/50**

41 AZP	●	—
41 N	○	

○  
NEUTRO (N)

●  
AZZURRO (AZP)



PRODOTTI IN  
MATERIALE  
RICICLABILE

# BAGNI OVALI

Oval basin



art.	Ø	Capacità Capacity	art.	Ø	Capacità Capacity
47/45	45	11 l	47/65	65	36 l
47/50	50	15 l	47/70	70	46 l
47/55	55	18 l	47/80	80	61 l
47/60	60	29 l			

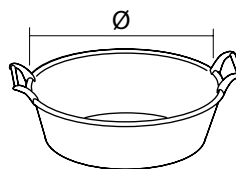

47/45



47/50



47/55



47/60



47/65



47/70



47/80

47 AZP	●	—
47 N	○	

○  
NEUTRO (N)

●  
AZZURRO (AZP)



PRODOTTI IN  
MATERIALE  
RICICLABILE

# MASTELLI 3 MANICI

THREE-ANGLE TUB

**CASALINGHI**  
Household

art.	Ø	Capacità Capacity	art.	Ø	Capacità Capacity
82/45	45	32 l	82/60	60	80 l
82/50	50	45 l	82/65	65	90 l
82/55	55	60 l	82/70	70	120 l

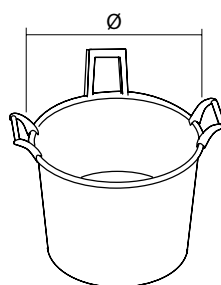

82 AZP ●

—

82 N ○





**82/45**



**82/50**



**82/55**



**82/60**



**82/65**



**82/70**

○  
NEUTRO (N)

●  
AZZURRO (AZP)



PRODOTTI IN  
MATERIALE  
RICICLABILE



# SECCHI NORMALI GRADUATI

*NORMAL BUCKET*

**CASALINGHI**  
Household

art.	Capacità Capacity
39/7	7 l
39/9	9 l
39/12	12 l
39/15	15 l

39 AZP ●

—

39 N ○



**39/07**



**39/09**



**39/12**



**39/15**

○  
NEUTRO (N)

●  
AZZURRO (AZP)



PRODOTTI IN  
MATERIALE  
RICICLABILE

# SECCHI CON BECCO GRADUATI

GRADUATED BUCKET WITH POURING LIP



art.	Capacità Capacity
42/9	9 l
42/12	12 l
42/15	15 l

42 AZP	●	—
42 N	○	



42/09



42/12



42/15

○ NEUTRO (N)      ● AZZURRO (AZP)



PRODOTTI IN  
MATERIALE  
RICICLABILE

# SCOLAPASTA

## COLANDER

**CASALINGHI**

Household

art.	Ø
109/22	22
109/26	26
109/30	30
12	18

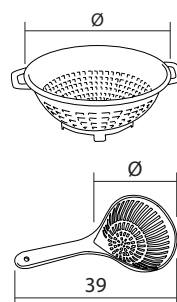

○  
BIANCO (BIM)



PRODOTTI IN  
MATERIALE  
RICICLABILE

# INSALATIÈRE

## SALAD BOWL



art.	Ø	art.	Ø
50/16	16	50/26	26
50/18	18	50/28	28
50/20	20	50/30	30
50/22	22	50/32	32
50/24	24	50/34	34

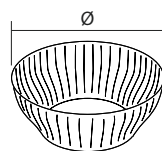

**50/16**



**50/18**



**50/20**



**50/22**



**50/24**



**50/26**



**50/28**



**50/30**



**50/32**



**50/34**



BIANCO (BIM)



PRODOTTI IN  
MATERIALE  
RICICLABILE

# PERSONALIZZAZIONI

## PRIVATE LABEL

Disponibilità a fornire su richiesta loghi personalizzati e/o colori non presenti a catalogo.  
Prodotti in materiale autoestinguente a norma UL 94.  
Quantità e prezzi da concordare.

*For special requests of non-standard colours.  
Items made of self-extinguishing materials as by UL 94.  
Prices and quantities have to be agreed.*



# LEGENDA

## LEGEND

### Materiali / Material

- PET** polietilene tereftalato / *polyethylene terephthalate*
- PP** polipropilene / *polypropylene*
- PST** polistirolo / *polystyrene*
- HD PE** polietilene alta densità / *high density polyethylene*
- LD PE** polietilene bassa densità / *low density polyethylene*
- ABS** acrilonitrile-butadiene-stirene / *acrylonitrile-butadiene-styrene*

### Simboli / Symbols



tutti gli articoli contrassegnati dal simbolo alimentare, sono conformi alle direttive ce n. 1935/2004 e regolamenti d.m. n. 34 del 21-03-73  
*all items marked with the food use logo, are in conformity with n. 1935/2004 and d.m. n. 34/21-03-73*

### Colori / Colors

- |  |  |
|--|--|
| ARA = aragosta / <i>bright orange</i>          | GC = grigio chiaro / <i>light grey</i>             |
| AZP = azzurro politene / <i>polythene blue</i> | GS = grigio scuro / <i>anthracite grey</i>         |
| BIL = bianco latte / <i>milky white</i>        | GRN = grigio-nero / <i>grey-black</i>              |
| BIM = bianco / <i>white</i>                    | N = neutro / <i>neutral</i>                        |
| BL = blu / <i>blue</i>                         | NE = nero / <i>black</i>                           |
| BLB = blu bidone / <i>bin blue</i>             | NER = nero / <i>black</i>                          |
| BRB = bruno bidone / <i>bin brown</i>          | RO = rosso / <i>red</i>                            |
| BRR = bruno rame / <i>copper brown</i>         | ROB = rosso bidone / <i>bin red</i>                |
| GI = giallo / <i>yellow</i>                    | ROM = rosso / <i>red</i>                           |
| GIA = giallo / <i>yellow</i>                   | TR = trasparente / <i>transparent</i>              |
| GR = grigio / <i>grey</i>                      | TS = bianco trasparente / <i>transparent white</i> |
| GRB = grigio bidone / <i>bin grey</i>          | VE = verde / <i>green</i>                          |
| GRB-BLB = grigio-blu / <i>grey-blue</i>        | VEB = verde bidone / <i>bin green</i>              |
| GRB-GIA = grigio-giallo / <i>grey-yellow</i>   | VEI = verde industriale / <i>industrial green</i>  |
| GRB-ROB = grigio-rosso / <i>grey-red</i>       | VES = verde scuro / <i>dark green</i>              |
| GRB-VES = grigio-verde / <i>grey-green</i>     | VIN = vinaccia / <i>grape red</i>                  |
| GRI = grigio / <i>grey</i>                     | VET = verde / <i>green</i>                         |

### Misure / Size

#### L - P - H

Misure massimo ingombro dell'articolo.  
*Maximun external dimensions of the article.*

#### l - p - h

Misura utile interna del singolo cassetto.  
*Practical internal dimension of single drawer.*

# DATI TECNICI

## TECHNICAL DATA

FERRAMENTA & MAGAZZINO						
Articolo	Codice Ean	Colore	Per alim.	Imb. (Pz)	Imb. (Kg)	Pezzi pallet
<b>serie 2000</b>						
BIN2001.VE	8000919000315	Verde	—	100	4,50	3.000
BIN2001.RO	8000919001688	Rosso	—	100	4,50	3.000
BIN2001.GI	8000919007345	Giallo	—	100	4,50	3.000
BIN2001.BL	8000919001350	Blu	—	100	4,50	3.000
BIN2001.GR	8000919008489	Grigio	—	100	4,50	3.000
BIN2001B.VE	8000919001862	Verde	—	100	6,30	1.200
BIN2001B.RO	8000919005303	Rosso	—	100	6,30	1.200
BIN2001B.GI	8000919005662	Giallo	—	100	6,30	1.200
BIN2001B.BL	8000919005655	Blu	—	100	6,30	1.200
BIN2001B.GR	8000919005679	Grigio	—	100	6,30	1.200
BIN2002.VE	8000919000322	Verde	—	48	4,40	1.728
BIN2002.RO	8000919001695	Rosso	—	48	4,40	1.728
BIN2002.GI	8000919009400	Giallo	—	48	4,40	1.728
BIN2002.BL	8000919001367	Blu	—	48	4,40	1.728
BIN2002.GR	8000919009417	Grigio	—	48	4,40	1.728
BIN2002L.VE	8000919003729	Verde	—	28	4,40	1.008
BIN2002L.RO	8000919005723	Rosso	—	28	4,40	1.008
BIN2002L.GI	8000919005709	Giallo	—	28	4,40	1.008
BIN2002L.BL	8000919005693	Blu	—	28	4,40	1.008
BIN2002L.GR	8000919005716	Grigio	—	28	4,40	1.008
BIN2003.VE	8000919000339	Verde	—	38	8,60	608
BIN2003.RO	8000919001701	Rosso	—	38	8,60	608
BIN2003.GI	8000919009707	Giallo	—	38	8,60	608
BIN2003.BL	8000919001374	Blu	—	38	8,60	608
BIN2003.GR	8000919009714	Grigio	—	38	8,60	608
BIN2003L.VE	8000919003736	Verde	—	16	5,80	352
BIN2003L.RO	8000919005785	Rosso	—	16	5,80	352
BIN2003L.GI	8000919005778	Giallo	—	16	5,80	352
BIN2003L.BL	8000919005761	Blu	—	16	5,80	352
BIN2003L.GR	8000919005297	Grigio	—	16	5,80	352
BIN2004.VE	8000919000346	Verde	—	20	10,30	160
BIN2004.RO	8000919001718	Rosso	—	20	10,30	160
BIN2004.GI	8000919009981	Giallo	—	20	10,30	160
BIN2004.BL	8000919001381	Blu	—	20	10,30	160
BIN2004.GR	8000919009998	Grigio	—	20	10,30	160
BIN2005.VE	8000919000353	Verde	—	12	13,80	96
BIN2005.RO	8000919002524	Rosso	—	12	13,80	96
BIN2005.GI	8000919010130	Giallo	—	12	13,80	96
BIN2005.BL	8000919003835	Blu	—	12	13,80	96
BIN2005.GR	8000919004085	Grigio	—	12	13,80	96
BIN2005S.VE	8000919003392	Verde	—	4	9,30	44
BIN2005S.RO	8000919010253	Rosso	—	4	9,30	44
BIN2005S.GI	8000919010222	Giallo	—	4	9,30	44
BIN2005S.BL	8000919003842	Blu	—	4	9,30	44

BIN2005S.GR	8000919005822	Grigio	—	4	9,30	44
COP2001.TR	8000919005846	Trasparente	—	—	—	—
COP2001B.TR	8000919005853	Trasparente	—	—	—	—
COP2002.TR	8000919005860	Trasparente	—	—	—	—
<b>serie C500</b>						
BINC502.VE	8000919000612	Verde	—	48	5,42	1.728
BINC502.BL	8000919006645	Blu	—	48	5,42	1.728
BINC502.VE	8000919000612	Verde	—	48	5,42	1.728
BINC502.BL	8000919006645	Blu	—	48	5,42	1.728
BINC502.RO	8000919006676	Rosso	—	48	5,42	1.728
BINC503.VE	8000919000629	Verde	—	38	11,09	608
BINC503.BL	8000919006683	Blu	—	38	11,09	608
BINC503.RO	8000919006713	Rosso	—	38	11,09	608
BINC504.VE	8000919000636	Verde	—	24	15,10	168
BINC504.BL	8000919006720	Blu	—	24	15,10	168
BINC504.RO	8000919006744	Rosso	—	24	15,10	168
BINC505.VE	8000919000643	Verde	—	12	16,00	48
BINC505.BL	8000919006751	Blu	—	12	16,00	48
BINC505.RO	8000919006775	Rosso	—	12	16,00	48
BINC505S.VE	8000919003422	Verde	—	4	9,40	44
BINC505S.BL	8000919006782	Blu	—	4	9,40	44
BINC505S.RO	8000919006812	Rosso	—	4	9,40	44
<b>serie KOMBI</b>						
BIN1PST.VE	8000919000476	Verde	—	100	5,30	3.000
BIN2K.VE	8000919000483	Verde	—	48	5,70	1.728
BIN3K.VE	8000919000490	Verde	—	38	10,26	608
BIN3KB.VE	8000919000506	Verde	—	24	12,10	384
BIN3KBD.VE	8000919006416	Verde	—	24	12,80	384
BIN4K.VE	8000919000520	Verde	—	24	15,50	168
BIN5K.VE	8000919000537	Verde	—	12	15,90	96
BIN5KD.VE	8000919000957	Verde	—	12	18,10	96
BIN5KS.VE	8000919000988	Verde	—	4	10,20	44
BIN5KSD.VE	8000919000995	Verde	—	4	11,40	44
BIN6K.VE	8000919000964	Verde	—	4	16,00	16
BIN6KD.VE	8000919000971	Verde	—	4	18,00	16
PAT4K.TR	8000919006515	Trasparente	—	—	—	—
PAT5K.TR	8000919006522	Trasparente	—	—	—	—
<b>PENSIL</b>						
MP45.RO	8000919003224	Rosso	—	2	4,50	3.000
MP90.RO	8000919002319	Rosso	—	2	4,50	3.000
<b>CARRELLI</b>						
MP30C.RO	8000919009196	Rosso	—	1	33,80	—
KITMP30C.MX	8000919011304	MIX	—	1	6,40	—
MP60CR.RO	8000919002227	Rosso	—	1	42,00	—
KITMP60.MX	8000919004160	MIX	—	1	13,00	—
<b>serie EUROPA 400x300</b>						
2210-GRI	8004331221013	Grigio	—	1	x	168

# DATI TECNICI

## TECHNICAL DATA

FERRAMENTA & MAGAZZINO						
Articolo	Codice Ean	Colore	Per alim.	Imb. (Pz)	Imb. (Kg)	Pezzi pallet
2213-GRI	8004331221310	Grigio	—	1	0,63	144
2217-GRI	8004331221716	Grigio	—	1	0,68	104
2222-GRI	8004331222218	Grigio	—	1	0,81	80
2232-GRI	8004331223215	Grigio	—	1	0,96	56
2200-GRI	8004331220016	Grigio	—	1	1,25	448
2200C-GRI	8004331220030	Grigio	—	1	0,4	480
serie EUROPA 600x400						
4407-GRI	8004331443323	Grigio	—	1	1,03	148
4410-GRI	8004331441015	Grigio	—	1	1,4	104
4413-GRI	8004331441312	Grigio	—	1	1,59	76
4417-GRI	8004331441718	Grigio	—	1	1,87	56
4422-GRI	8004331442210	Grigio	—	1	2,12	40
4432-GRI	8004331443224	Grigio	—	1	2,73	28
4400-GRI	8004331440018	Grigio	—	1	0,67	400
CASSE MULTIUSO con coperchio						
143/20-GRI	8004331143223	Grigio	—	6	6,9	84
143/40-GRI	8004331143421	Grigio	—	6	11,7	48
143/60-GRI	8004331143629	Grigio	—	4	9,66	32
CRYSTAL BOX						
CB50/2S.BL	8000919003866	Blu	—	1	1,8	3.000
CB50/2S.GC	8000919003743	Grigio chiaro	—	1	1,8	3.000
CB50/2S.GS	8000919003859	Grigio scuro	—	1	1,8	3.000
CB50/3.BL	8000919003873	Blu	—	2	2,2	3.000
CB50/3.GC	8000919009813	Grigio chiaro	—	2	2,2	3.000
CB50/3.GS	8000919009820	Grigio scuro	—	2	2,2	1.200
CB50/3S.BL	8000919004559	Blu	—	1	2,4	1.200
CB50/3S.GC	8000919009837	Grigio chiaro	—	1	2,4	1.200
CB50/3S.GS	8000919009844	Grigio scuro	—	1	2,4	1.200
CB50/4S.BL	8000919004566	Blu	—	1	3,3	1.200
CB50/4S.GC	8000919009851	Grigio chiaro	—	1	3,3	1.728
CB50/4S.GS	8000919009868	Grigio scuro	—	1	3,3	1.728
CB50/5S.BL	8000919004573	Blu	—	1	4,7	1.728
CB50/5S.GC	8000919009875	Grigio chiaro	—	1	4,7	1.728
CB50/5S.GS	8000919009882	Grigio scuro	—	1	4,7	1.728
FERCB2S	8000919010758	Grigio	—	1	—	1.008
FERCB3	8000919003484	Grigio	—	1	—	1.008
FERCB3S	8000919004979	Grigio	—	1	—	1.008
FERCB4S	8000919004986	Grigio	—	1	—	1.008
FERCB5S	8000919004993	Grigio	—	1	—	1.008
VASCB50/2S.TR	8000919004955	Trasparente	—	1	0,05	608
VASCB50/3S.TR	8000919004962	Trasparente	—	1	0,14	608
CRYSTAL BOX TELAI						
MP100.GR	8000919001435	Grigio	—	2	7,8	—
MP125.GR	8000919001855	Grigio	—	1	5,6	—

MP150.GR	8000919001831	Grigio	—	1	12,0	—
MP175.GR	8000919001824	Grigio	—	1	12,2	—
MP195.GR	8000919001848	Grigio	—	1	13,7	—
CRYSTAL BOX SCAFFALI						
CB200.BL	8000919002937	Blu	—	1	46,00	—
CB200.GC	8000919003576	Grigio chiaro	—	1	46,00	—
CB200.GS	8000919003651	Grigio scuro	—	1	46,00	—
CB200A.BL	8000919007246	Blu	—	1	57,00	—
CB200A.GC	8000919007185	Grigio chiaro	—	1	57,00	—
CB200A.GS	8000919007901	Grigio scuro	—	1	57,00	—
CB200D.BL	8000919002951	Blu	—	1	80,00	—
CB200D.GC	8000919003675	Grigio chiaro	—	1	80,00	—
CB200D.GS	8000919003705	Grigio scuro	—	1	80,00	—
CB200DA.BL	8000919008830	Blu	—	1	97,00	—
CB200DA.GC	8000919010284	Grigio chiaro	—	1	97,00	—
CB200DA.GS	8000919010291	Grigio scuro	—	1	97,00	—
CRYSTAL BOX ARMADI						
CB400.1.BL	8000919010307	Blu	—	1	140	—
CB400.1.GC	8000919010314	Grigio chiaro	—	1	140	—
CB400.1.GS	8000919010321	Grigio scuro	—	1	140	—
CB400.1A.BL	8000919010338	Blu	—	1	140	—
CB400.1A.GC	8000919010345	Grigio chiaro	—	1	140	—
CB400.1A.GS	8000919010352	Grigio scuro	—	1	140	—
CB400.1B.BL	8000919010369	Blu	—	1	140	—
CB400.1B.GC	8000919010376	Grigio chiaro	—	1	140	—
CB400.1B.GS	8000919010383	Grigio scuro	—	1	140	—
CB400.2.BL	8000919002968	Blu	—	1	190	—
CB400.2.GC	8000919005006	Grigio chiaro	—	1	190	—
CB400.2.GS	8000919005037	Grigio scuro	—	1	190	—
CB400.2A.BL	8000919002975	Blu	—	1	190	—
CB400.2A.GC	8000919005044	Grigio chiaro	—	1	190	—
CB400.2A.GS	8000919005051	Grigio scuro	—	1	190	—
CB400.2B.BL	8000919003309	Blu	—	1	190	—
CB400.2B.GC	8000919005068	Grigio chiaro	—	1	190	—
CB400.2B.GS	8000919005099	Grigio scuro	—	1	190	—
CB400.3.BL	8000919010390	Blu	—	1	243	—
CB400.3.GC	8000919010406	Grigio chiaro	—	1	243	—
CB400.3.GS	8000919010413	Grigio scuro	—	1	243	—
CB400.3A.BL	8000919010420	Blu	—	1	243	—
CB400.3A.GC	8000919010437	Grigio chiaro	—	1	243	—
CB400.3A.GS	8000919010444	Grigio scuro	—	1	243	—
CB400.3B.BL	8000919010451	Blu	—	1	243	—
CB400.3B.GC	8000919010468	Grigio chiaro	—	1	243	—
CB400.3B.GS	8000919010475	Grigio scuro	—	1	243	—
CB400.3C.BL	8000919010482	Blu	—	1	243	—
CB400.3C.GC	8000919010499	Grigio chiaro	—	1	243	—
CB400.3C.GS	8000919010505	Grigio scuro	—	1	243	—
CB600.4.BL	8000919010512	Blu	—	1	310	—



# DATI TECNICI

## TECHNICAL DATA

### FERRAMENTA & MAGAZZINO

Articolo	Codice Ean	Colore	Per alim.	Imb. (Pz)	Imb. (Kg)	Pezzi pallet
CB600.4.GC	8000919010529	Grigio chiaro	—	1	310	—
CB600.4.GS	8000919010536	Grigio scuro	—	1	310	—
CB600.4A.BL	8000919010543	Blu	—	1	310	—
CB600.4A.GC	8000919010550	Grigio chiaro	—	1	310	—
CB600.4A.GS	8000919010567	Grigio scuro	—	1	310	—
CB600.4B.BL	8000919010574	Blu	—	1	310	—
CB600.4B.GC	8000919010581	Grigio chiaro	—	1	310	—
CB600.4B.GS	8000919010598	Grigio scuro	—	1	310	—
CB600.4C.BL	8000919010604	Blu	—	1	310	—
CB600.4C.GC	8000919010611	Grigio chiaro	—	1	310	—
CB600.4C.GS	8000919010628	Grigio scuro	—	1	310	—
CB600.6.BL	8009190105635	Blu	—	1	320	—
CB600.6.GC	8000919010642	Grigio chiaro	—	1	320	—
CB600.6.GS	8000919010659	Grigio scuro	—	1	320	—
CB600.6A.BL	8000919010666	Blu	—	1	320	—
CB600.6A.GC	8000919010673	Grigio chiaro	—	1	320	—
CB600.6A.GS	8000919010680	Grigio scuro	—	1	320	—
CB600.6B.BL	8000919010697	Blu	—	1	320	—
CB600.6B.GC	8000919010703	Grigio chiaro	—	1	320	—
CB600.6B.GS	8000919010710	Grigio scuro	—	1	320	—
CB600.6C.BL	8000919010727	Blu	—	1	320	—
CB600.6C.GC	8000919010734	Grigio chiaro	—	1	320	—
CB600.6C.GS	8000919010741	Grigio scuro	—	1	320	—

### ACCESSORI

LEDCB400	8000919003545	Bianco freddo	—	1	—	—
----------	---------------	---------------	---	---	---	---

### CRYSTAL BOX CARRELLO

CB30.GR	8000919003408	Grigio	—	1	17,00	—
---------	---------------	--------	---	---	-------	---

### C-MINI CASSETTIERE componibili MINI

COMA.VE	8000919000001	Verde	—	6	6,80	264
COMTA.TR	8000919000087	Trasparente	—	6	6,80	264
COMA1.VE	8000919000018	Verde	—	6	6,40	264
COMTA1.TR	8000919000094	Trasparente	—	6	6,40	264
COMB.VE	8000919000025	Verde	—	6	5,80	264
COMTB.TR	8000919000100	Trasparente	—	6	5,80	264
COMC.VE	8000919000032	Verde	—	6	5,30	264
COMTC.TR	8000919000117	Trasparente	—	6	5,30	264
COMD.VE	8000919000049	Verde	—	6	4,80	264
COMTD.TR	8000919000124	Trasparente	—	6	4,80	264
COMM.VE	8000919000056	Verde	—	6	5,70	264
COMTM.TR	8000919000148	Trasparente	—	6	5,70	264
VASA.BI	8000919003620	Bianco	—	—	—	—
VASA1.BI	8000919002531	Bianco	—	—	—	—
VASB.BI	8000919003637	Bianco	—	—	—	—
VASC.BI	8000919002548	Bianco	—	—	—	—

VASD.BI	8000919002555	Bianco	—	—	—	—
---------	---------------	--------	---	---	---	---

### C-MIDI CASSETTIERE componibili MIDI

COMT42.TR	8000919001190	Trasparente	—	8	11,20	128
COMT43.TR	8000919001206	Trasparente	—	8	12,60	128
COMT44.TR	8000919001213	Trasparente	—	8	13,80	128
COMT45.TR	8000919001220	Trasparente	—	8	15,20	128

### C-MAXI CASSETTIERE componibili MAXI

COML.VE	8000919000179	Verde	—	1	2,4	96
COMTL.TR	8000919000186	Trasparente	—	8	19,3	64
COME.VE	8000919000605	Verde	—	1	4,9	48
COMTE.TR	8000919000544	Trasparente	—	1	5	48
COMF.VE	8000919000599	Verde	—	1	7,3	35
COMTF.TR	8000919001541	Trasparente	—	1	6,5	35
COMH3.VE	8000919002289	Verde	—	1	6,3	35
COMT3.TR	8000919001510	Trasparente	—	1	6,4	35
COMG.VE	8000919001558	Verde	—	1	5,2	40
COMMOB1.VE	8000919001022	Verde	—	1	3,6	40
COMMOB101.TR	8000919001015	Trasparente	—	1	3,6	40
COMMOB2.VE	8000919000155	Verde	—	8	11,3	112
COMMOB102.TR	8000919000162	Trasparente	—	8	11,2	112
COMMOB3.VE	8000919001534	Verde	—	1	5,7	35
COMMOB103.TR	8000919001527	Trasparente	—	1	5,6	35
COMMOB1T.VE	8000919002364	Verde	—	1	4,3	40
COMFT.VE	8000919001770	Verde	—	1	7,2	35
ESPPG.VE	8000919007536	Verde	—	—	—	—
BASE.NE	8000919007390	Nero	—	1	0,26	—
BASF.NE	8000919007406	Nero	—	1	0,54	—
BASG.NE	8000919007413	Nero	—	1	0,76	—
VASE.VE	8000919000940	Verde	—	—	—	—
VASF1VE	8000919001619	Verde	—	—	—	—
VASF2VE	8000919001626	Verde	—	—	—	—
VASF3.VE	8000919001633	Verde	—	—	—	—
VASG1.VE	8000919001640	Verde	—	—	—	—
VASH1.VE	8000919001657	Verde	—	—	—	—
VASH2.VE	8000919001664	Verde	—	—	—	—
VASH3.VE	8000919001671	Verde	—	—	—	—
COMS40.VE	8000919001985	Verde	—	1	3,4	60
COMS40T.VE	8000919002005	Verde	—	1	3,6	60
COMT40.TR	8000919001992	Trasparente	—	1	3,3	60

### CLASS ORGANIZER

CLASS9.TR	8000919002371	Trasparente	—	48	3,00	3.840
CLASS9VA.TR	8000919002388	Trasparente	—	48	4,20	3.840
CLASS10.TR	8000919002074	Trasparente	—	36	5,70	1.512
CLASS11.TR	8000919002081	Trasparente	—	24	6,10	864
CLASS12.TR	8000919002098	Trasparente	—	24	9,40	864
CLASS13.TR	8000919003590	Trasparente	—	18	5,50	432
CLASS14.TR	8000919003606	Trasparente	—	18	9,50	432

# DATI TECNICI

## TECHNICAL DATA

### FERRAMENTA & MAGAZZINO

Articolo	Codice Ean	Colore	Per alim.	Imb. (Pz)	Imb. (Kg)	Pezzi pallet
CLASS18.BL	8000919002401	Blu	—	16	3,10	1.280
CLASS19.BL	8000919002418	Blu	—	16	3,80	1.280
CLASS20.BL	8000919002104	Blu	—	12	3,60	648
CLASS22.BL	8000919002128	Blu	—	12	5,40	648
CLASS30.BL	8000919002135	Blu	—	6	4,00	288
CLASS31.BL	8000919002142	Blu	—	6	4,50	288
CLASS32.BL	8000919002159	Blu	—	6	5,40	288
CLASS41.BL	8000919002432	Blu	—	5	5,70	180
CLASS42.BL	8000919002449	Blu	—	5	7,00	180
VASCLASS1.TR	8000919002173	Trasparente	—	—	—	—
VASCLASS2.TR	8000919002180	Trasparente	—	—	—	—
VASCLASS3.TR	8000919002197	Trasparente	—	—	—	—
VASCLASS4.TR	8000919002517	Trasparente	—	—	—	—
VASCLASS5.TR	8000919002579	Trasparente	—	—	—	—
VASCLASS6.TR	8000919002586	Trasparente	—	—	—	—
VASCLASS7.TR	8000919002593	Trasparente	—	—	—	—
VASCLASS8.TR	8000919002609	Trasparente	—	—	—	—

### ESPACE CASSETTIERE

ESP12.BL	8000919001923	Blu	—	12	10,20	264
ESP20.BL	8000919001930	Blu	—	10	13,00	140
ESP30.BL	8000919001947	Blu	—	4	7,80	96

### PULIZIA & RACCOLTA DIFFERENZIATA

Articolo	Codice Ean	Colore	Per alim.	Imb. (Pz)	Imb. (Kg)	Pezzi pallet
----------	------------	--------	-----------	-----------	-----------	--------------

### BIDONI CARRELLATI 120 l

1/120/5-BIL	8004331112052	Bianco latte	—	1	9,00	24
1/120/5-BLB	8004331112151	Blu bidone	—	1	9,00	24
1/120/5-BRB	8004331112250	Bruno bidone	—	1	9,00	24
1/120/5-GIA	8004331112359	Giallo	—	1	9,00	24
1/120/5-GRB	8004331112458	Grigio bidone	—	1	9,00	24
1/120/5-ROB	8004331112557	Rosso bidone	—	1	9,00	24
1/120/5-VES	8004331112755	Verde scuro	—	1	9,00	24
1/120/5GRB-BLB	8004331112014	Grigio - Blu bid.	—	1	9,00	24
1/120/5GRB-GIA	8004331112212	Grigio - Giallo	—	1	9,00	24
1/120/5GRB-ROB	8004331112717	Grigio - Rosso bid.	—	1	9,00	24
1/120/5GRB-VES	8004331112762	Grigio - Verde sc.	—	1	9,00	24
1/120	8004331011201	—	—	1	0,30	—
1204	8004331112045	—	—	1	1,70	—
95/120	8004331951200	Nero	—	200	16,80	—

### BIDONI CARRELLATI 240 l

1/240/5-BIL	8004331124055	Bianco latte	—	1	13,50	15
1/240/5-BLB	8004331124154	Blu bidone	—	1	13,50	15
1/240/5-BRB	8004331124253	Bruno bidone	—	1	13,50	15
1/240/5-GIA	8004331124352	Giallo	—	1	13,50	15

1/240/5-GRB	8004331124451	Grigio bidone	—	1	13,50	15
1/240/5-ROB	8004331124550	Rosso bidone	—	1	13,50	15
1/240/5-VES	8004331124758	Verde scuro	—	1	13,50	15
1/240/5GRB-BLB	8004331124017	Grigio - Blu bid.	—	1	13,50	15
1/240/5GRB-GIA	8004331124215	Grigio - Giallo	—	1	13,50	15
1/240/5GRB-ROB	8004331124710	Grigio - Rosso bid.	—	1	13,50	15
1/240/5GRB-VES	8004331124765	Grigio - Verde sc.	—	1	13,50	15
1/240	8004331012406	—	—	1	0,55	—
2404	8004331124048	—	—	1	1,80	—
95/240	8004331952405	Nero	—	100	16,40	—

### SERRATURA GRAVITAZIONALE PER BIDONI CARRELLATI 120/240 l

1/111	8004331011119	Rosso	—	1	0,87	—
-------	---------------	-------	---	---	------	---

### BIDONI CARRELLATI 360 l

1/360/5-GRB	8004331013625	Grigio bidone	—	1	15,40	7
1/360/5-BLB	8004331013601	Blu bidone	—	1	15,40	7
1/360/5-VEB	8004331013649	Verde bidone	—	1	15,40	7
1/360/5-ROB	8004331013632	Rosso bidone	—	1	15,40	7
1/360/5-GIA	8004331013618	Giallo	—	1	15,40	7
1/360/5GRB-BLB	8004331013656	Grigio - Blu bid.	—	1	15,40	7
1/360/5GRB-GIA	8004331013663	Grigio - Giallo	—	1	15,40	7
1/360/5GRB-VEB	8004331013687	Grigio - Verde sc.	—	1	15,40	7
1/360/5GRB-ROB	8004331013670	Grigio - Rosso bid.	—	1	15,40	7

### BIDONI CARRELLATI 4 RUOTE 660 l

1/660/5-GRB	8004331016619	Grigio bidone	—	1	40,00	—
1/660/5-BLB	8004331016633	Blu bidone	—	1	40,00	—
1/660/5-VEB	8004331016626	Verde bidone	—	1	40,00	—
1/660/5-GIA	8004331016602	Giallo	—	1	40,00	—
1/660/5GRB-BLB	8004331016640	Grigio - Blu bid.	—	1	40,00	—
1/660/5GRB-GIA	8004331016657	Grigio - Giallo	—	1	40,00	—
1/660/5GRB-VEB	8004331016664	Grigio - Verde bid.	—	1	40,00	—
6604	8004331016671	—	—	1	3,50	—

### BIDONI CARRELLATI 4 RUOTE 760 l

1/770/5-GRB	8004331017715	Grigio bidone	—	1	43,00	—
1/770/5-BLB	8004331017739	Blu bidone	—	1	43,00	—
1/770/5-VEB	8004331017722	Verde bidone	—	1	43,00	—
1/770/5-GIA	8004331017708	Giallo	—	1	43,00	—
1/770/5GRB-BLB	8004331017746	Grigio - Blu bid.	—	1	43,00	—
1/770/5GRB-GIA	8004331017753	Grigio - Giallo	—	1	43,00	—
1/770/5GRB-VEB	8004331017760	Grigio - Verde bid.	—	1	43,00	—
7704	8004331017777	—	—	1	3,80	—

### BIDONI CARRELLATI 4 RUOTE 1100 l

1/1100/5-GRB	8004331011010	Grigio bidone	—	1	50,00	—
1/1100/5-BLB	8004331011034	Blu bidone	—	1	50,00	—
1/1100/5-VEB	8004331011027	Verde bidone	—	1	50,00	—
1/1100/5-GIA	8004331011003	Giallo	—	1	50,00	—
1/1100/5GRB-BLB	8004331011041	Grigio - Blu bid.	—	1	50,00	—
1/1100/5GRB-GIA	8004331011058	Grigio - Giallo	—	1	50,00	—

# DATI TECNICI

## TECHNICAL DATA

PULIZIA & RACCOLTA DIFFERENZIATA						
Articolo	Codice Ean	Colore	Per alim.	Imb. (Pz)	Imb. (Kg)	Pezzi pallet
1/1100/5GRB-VEB	8004331011065	Grigio - Verde bid.	—	1	50,00	—
11004	8004331011072	—	—	1	4,50	—
PORTARIFIUTI ECOLOGY 25/35 l						
11/25GRB-BLB	8004331112502	Grigio - Blu	—	1	1,30	72
11/25GRB-BRB	8004331112526	Grigio - Bruno	—	1	1,30	72
11/25GRB-GIA	8004331112533	Grigio - Giallo	—	1	1,30	72
11/25GRB-VEB	8004331112540	Grigio - Verde	—	1	1,30	72
11/35GRB-BLB	8004331113509	Grigio - Blu	—	1	1,50	72
11/35GRB-BRB	8004331113516	Grigio - Bruno	—	1	1,50	72
11/35GRB-GIA	8004331113523	Grigio - Giallo	—	1	1,50	72
11/35GRB-VEB	8004331113530	Grigio - Verde	—	1	1,50	72
PULIZIA						
107/30-BRR	8004331107324	Bruno rame	—	10	3,90	432
107/30-GRI	8004331107331	Grigio nero	—	10	3,90	432
107/30-NER	8004331107348	Nero	—	10	3,90	432
90-BRR	8004331090022	Bruno rame	—	12	3,90	432
124/23-BRR	8004331124239	Bruno rame	—	6	0,48	—
BIDONE DUSTY 25 l						
105/25-BLB	8004331105252	Grigio - Blu	—	5	5,52	90
105/25-GIA	8004331105269	Grigio - Giallo	—	5	5,52	90
105/25-ROB	8004331105276	Grigio - Rosso	—	5	5,52	90
105/25-VEB	8004331105283	Grigio - Verde sc.	—	5	5,52	90
BIDONE 80 80 l						
80-BIL	8004331000816	Bianco latte	—	1	2,92	40
80-BLB	8004331000823	Grigio - Blu	—	1	2,92	40
80-GIA	8004331000830	Grigio - Giallo	—	1	2,92	40
80-ROB	8004331000847	Grigio - Rosso	—	1	2,92	40
80-VEB	8004331000854	Grigio - Verde sc.	—	1	2,92	40
804	8004331000861	—	—	1	1,00	—
95/80	8004331095089	Nero	—	300	20,70	—
BIDONE 100 100 l						
100-VEB	8004331001035	Grigio - Verde sc.	—	1	3,70	32
100-GIA	8004331001011	Grigio - Giallo	—	1	3,70	32
100-ROB	8004331001028	Grigio - Rosso	—	1	3,70	32
100-BLB	8004331001004	Grigio - Blu	—	1	3,70	32
95/120	8004331951200	Nero	—	200	16,80	—
BIDONE 100 PUSH 100 l						
100P-VEB	8004331001073	Grigio - Verde sc.	—	1	3,70	24
100P-GIA	8004331001059	Grigio - Giallo	—	1	3,70	24
100P-ROB	8004331001066	Grigio - Rosso	—	1	3,70	24
100P-BLB	8004331001042	Grigio - Blu	—	1	3,70	24
95/120	8004331951200	Nero	—	200	16,80	—
BIDONE NELLO 80 l						
151-BIL	8004331015100	Bianco latte	—	1	6,20	32

151-GRN	8004331015148	Grigio	—	1	6,20	32
95/80	8004331095089	Nero	—	300	20,70	—
TRESPOLO 110 l						
69/110-VEB	8004331069004	Verde scuro	—	1	2,43	88
69/110-GRB	8004331069011	Grigio bidone	—	1	2,43	88
69/110GRB-VEB	8004331069080	Grigio - Verde sc.	—	1	2,43	88
69/110GRB-GIA	8004331069066	Grigio - Giallo	—	1	2,43	88
69/110GRB-ROB	8004331069073	Grigio - Rosso	—	1	2,43	88
69/110GRB-BLB	8004331069059	Grigio - Blu	—	1	2,43	88
95/120	8004331951200	Nero	—	200	16,80	—
ECO-AIR 4						
100/4-GR	8000919008069	Grigio	—	1	21,00	10
KIT100/4-MIX	8000919009585	—	—	1	2,61	—
BIDONE 91 60/80/100 l						
91/060-NER	8004331091616	Nero	—	1	3,45	72
91/080-NER	8004331091814	Nero	—	1	4,55	60
91/100-NER	8004331911013	Nero	—	1	5,45	35
95/1	8004331095010	Nero	—	300	12,60	—
BIDONI INDUSTRIALI DA 35 A 200 l						
8/0035-NER	8004331800355	Nero	—	1	1,50	120
8/0050-NER	8004331800508	Nero	—	1	2,06	85
8/0075-NER	8004331800751	Nero	—	1	3,00	60
BIDONI INDUSTRIALI DA 35 A 200 l						
8/0100-NER	8004331801000	Nero	—	1	4,00	50
8/0150-NER	8004331801505	Nero	—	1	5,00	40
8/0200-NER	8004331802007	Nero	—	1	6,06	18
77/035-NER	8004331770351	Nero	—	10	5,30	450
77/050-NER	8004331770504	Nero	—	10	6,40	380
77/075-NER	8004331770757	Nero	—	10	7,60	300
77/100-NER	8004331771006	Nero	—	10	9,60	300
77/150-NER	8004331771501	Nero	—	1	0,90	170
77/200-NER	8004331772003	Nero	—	1	1,00	150
BIDONI INDUSTRIALI DA 35 A 300 l						
92/035-VEI	8004331092361	Verde indust.	—	10	1,45	120
92/050-VEI	8004331092514	Verde indust.	—	10	2,20	85
92/075-VEI	8004331092767	Verde indust.	—	10	3,00	60
92/100-VEI	8004331921012	Verde indust.	—	10	3,85	50
92/150-VEI	8004331921517	Verde indust.	—	1	4,80	40
92/200-VEI	8004331922019	Verde indust.	—	1	5,30	18
92/300-VEI	8004331923009	Verde indust.	—	1	7,50	—
27/035-VEI	8004331027363	Verde indust.	—	10	5,30	450
27/050-VEI	8004331027516	Verde indust.	—	10	6,40	380
27/075-VEI	8004331027769	Verde indust.	—	10	7,60	300
27/100-VEI	8004331271018	Verde indust.	—	10	9,60	300
27/150-VEI	8004331271513	Verde indust.	—	1	0,90	170
27/200-VEI	8004331272015	Verde indust.	—	1	1,00	150
27/300-VEI	8004331273005	Verde indust.	—	1	1,33	—

# DATI TECNICI

## TECHNICAL DATA

### ENOLOGIA & AGRICOLTURA

Articolo	Codice Ean	Colore	Per alim.	Imb. (Pz)	Imb. (Kg)	Pezzi pallet
<b>CASSE INSERIBILI E SOVRAPPONIBILI</b>						
131/50-ARA	8004331131510	Aragosta		1	1,57	84
131/65-ARA	8004331131664	Aragosta		1	1,96	96
133/50-ARA	8004331133514	Aragosta		10	7,50	400
133/65-ARA	8004331133668	Aragosta		10	9,50	400
<b>MASTELLI CANTINA</b>						
2/0110-VIN	8004331021101	Vinaccia		1	4,15	24
2/0225-VIN	8004331022252	Vinaccia		1	5,80	15
2/0275-VIN	8004331022757	Vinaccia		1	6,99	21
2/0350-VIN	8004331023501	Vinaccia		1	9,50	21
2/0500-VIN	8004331025000	Vinaccia		1	11,00	19
2/0700-VIN	8004331027004	Vinaccia		1	19,00	16
2/1000-VIN	8004331210000	Vinaccia		1	26,00	8
32/500-VIN	8004331325018	Vinaccia		1	3,55	25
32/700-VIN	8004331327012	Vinaccia		1	4,45	—
17-GRC	8004331017012	Grigio chiaro		10	1,75	—
20/1	8004331020012	—		20	6,40	1280
150	8004331150009	—	—	—	—	—
<b>BIDONI CANTINA</b>						
13/150-VIN	8004331131527	Vinaccia		1	4,50	40
13/200-VIN	8004331132005	Vinaccia		1	5,66	18
13/300-VIN	8004331133002	Vinaccia		1	7,90	18
32/150-VIN	8004331321508	Vinaccia		1	0,81	170
32/200-VIN	8004331322000	Vinaccia		1	1,00	150
32/300-VIN	8004331323007	Vinaccia		1	1,20	100
20/3/4	8004331020340	—		—	0,03	—
<b>ALTRO ENOLOGIA</b>						
53-ARA	8004331053003	Aragosta		5	4,30	270
53/F-ARA	8004331053102	Aragosta		5	4,15	270
74-ARA	8004331074008	Aragosta		5	5,01	275
74/F-ARA	8004331074107	Aragosta		5	5,49	275
126-ARA	8004331126509	Aragosta		1	1,50	—
63-N	8004331063002	Neutro		1	0,06	1600
67-BRR	8004331067000	Bruno rame	—	10	6,75	120
23-ROM	8004331023013	Rosso	—	10	3,66	160
23-VET	8004331023037	Verde tedesco	—	10	3,66	160
24-ROM	8004331024010	Rosso	—	10	4,40	120
24-VET	8004331024034	Verde tedesco	—	10	4,40	120
<b>MASTELLI AGRICOLTURA</b>						
8/0110-NER	8004331801109	Nero	—	1	4,02	24
8/0225-NER	8004331802250	Nero	—	1	5,80	15
8/0350-NER	8004331803509	Nero	—	1	8,85	21
8/0500-NER	8004331805008	Nero	—	1	11,20	21
8/0700-NER	8004331807002	Nero	—	1	19,00	19

8/1000-NER	8004331810002	Nero	—	1	26,00	8
77/500-NER	8004331775004	Nero	—	1	3,65	8
77/700-NER	8004331777008	Nero	—	1	5,00	—
<b>INNAFFIATOI</b>						
87/02-VET	8004331087039	Verde tedesco	—	6	1,38	252
87/02-ROM	8004331087015	Rosso bidone	—	6	1,38	252
87/04-VET	8004331087053	Verde tedesco	—	5	1,45	180
87/04-ROM	8004331087060	Rosso bidone	—	5	1,45	180
87/08-VET	8004331087091	Verde tedesco	—	4	1,84	100
87/08-ROM	8004331087107	Rosso bidone	—	4	1,84	100
87/12-VET	8004331087138	Verde tedesco	—	4	3,02	80
87/12-ROM	8004331087145	Rosso bidone	—	4	3,02	80
87/16-VET	8004331087176	Verde tedesco	—	4	3,56	48
87/16-ROM	8004331087183	Rosso bidone	—	4	3,56	48

### TRASPORTO LIQUIDI & INDUSTRIA ALIMENTARE

Articolo	Codice Ean	Colore	Per alim.	Imb. (Pz)	Imb. (Kg)	Pezzi pallet
<b>TANICHE</b>						
61-N	8004331061008	Neutro		5	2,31	240
73/10-N	8004331073100	Neutro		7	3,12	126
73/20-N	8004331073209	Neutro		6	4,80	60
125/01-N	8004331125014	Neutro		10	0,60	1100
125/02-N	8004331125021	Neutro		4	0,50	560
125/03-N	8004331125038	Neutro		4	0,60	448
125/05-N	8004331125052	Neutro		10	2,32	320
125/10-N	8004331125106	Neutro		8	3,60	160
125/15-N	8004331125151	Neutro		7	3,95	112
125/20-N	8004331125205	Neutro		6	4,32	84
125/25-N	8004331125250	Neutro		4	3,68	60
125/30-N	8004331125304	Neutro		4	4,14	56
115/05-VES	8004331115053	Verde scuro	—	10	4,60	200
115/10-VES	8004331115107	Verde scuro	—	6	4,00	132
<b>FUSTINI A BOTTICELLA</b>						
97/005-N	8004331097052	Neutro		1	0,40	168
97/010-N	8004331097106	Neutro		1	0,50	105
97/015-N	8004331097151	Neutro		1	0,80	72
97/020-N	8004331097205	Neutro		1	0,93	66
97/025-N	8004331097250	Neutro		1	1,13	55
97/050-N	8004331097502	Neutro		1	2,00	24
97/100-N	8004331971000	Neutro		1	3,40	12
20/1/4	8004331020043	—		—	0,02	—
<b>BIDONI COLLO LARGO</b>						
78/02-N	8004331078020	Neutro		1	0,24	420
78/05-N	8004331078051	Neutro		1	0,38	204
78/10-N	8004331078105	Neutro		1	0,57	100
<b>BIDONI INDUSTRIALI CON CHIUSURA AD ANELLO</b>						
18/075-N	8004331018750	Neutro		1	4,00	—

# DATI TECNICI

## TECHNICAL DATA

### TRASPORTO LIQUIDI & INDUSTRIA ALIMENTARE

Articolo	Codice Ean	Colore	Per alim.	Imb. (Pz)	Imb. (Kg)	Pezzi pallet
18/100-N	8004331181003	Neutro		1	4,82	—
<b>BIDONI INDUSTRIALI DA 35 A 300 l</b>						
19/035-N	8004331019351	Neutro		1	1,49	120
19/050-N	8004331019504	Neutro		1	2,04	85
19/075-N	8004331019757	Neutro		1	2,78	60
19/100-N	8004331191002	Neutro		1	3,67	50
19/150-N	8004331191507	Neutro		1	4,33	40
19/200-N	8004331192009	Neutro		1	5,76	18
19/300-N	8004331193006	Neutro		1	7,47	18
59/035-N	8004331059357	Neutro		10	5,30	630
59/050-N	8004331059500	Neutro		10	6,40	300
59/075-N	8004331059753	Neutro		10	7,60	280
59/100-N	8004331591000	Neutro		10	9,60	280
59/150-N	8004331591505	Neutro		1	0,90	170
59/200-N	8004331592007	Neutro		1	1,00	150
59/300-N	8004331593004	Neutro		1	1,30	100
19/1	8004331001912	—	—	1	3,10	—
<b>CASSE INSERIBILI E SOVRAPPONIBILI</b>						
131/50-N	8004331131503	Neutro		1	1,61	84
131/65-N	8004331131657	Neutro		1	1,96	96
131/90-N	8004331131909	Neutro		1	3,00	54
132/50-N	8004331132500	Neutro		1	1,50	84
132/65-N	8004331132654	Neutro		1	1,95	84
133/50-N	8004331133507	Neutro		10	7,56	400
133/65-N	8004331133651	Neutro		10	9,50	400
133/90-N	8004331133903	Neutro		10	12,20	150
<b>FOOD BOX INSERIBILI E SOVRAPPONIBILI</b>						
143/20-BIM	8004331143209	Bianco		6	6,99	84
143/20-TS	8004331143216	Trasparente		6	6,99	84
143/40-BIM	8004331143407	Bianco		6	11,49	48
143/40-TS	8004331143414	Trasparente		6	11,49	48
143/60-BIM	8004331143605	Bianco		4	9,20	32
143/60-TS	8004331143612	Trasparente		4	9,20	32
<b>LIGHT BOX</b>						
5908-BIM	8004331059081	Bianco		1	1,05	84
5911-BIM	8004331059111	Bianco		1	1,19	60
5900-BIM	8004331059005	Bianco		12	0,72	—
5900-TS	8004331059012	Trasparente		12	0,72	—
<b>CASSA ALIMENTARE 400x300</b>						
2210-N	8004331221006	Neutro		1	0,61	168
2213-N	8004331221303	Neutro		1	0,66	144
2217-N	8004331221709	Neutro		1	0,78	104
2222-N	8004331222201	Neutro		1	0,92	80
2232-N	8004331223208	Neutro		1	1,23	56

2200-N	8004331220009	Neutro		1	0,39	448
2200C-N	8004331220023	Neutro		1	0,4	480
<b>CASSA ALIMENTARE 600x400</b>						
4407-N	8004331440704	Neutro		1	1,07	148
4410-N	8004331441008	Neutro		1	1,444	104
4413-N	8004331441305	Neutro		1	1,742	76
4417-N	8004331441701	Neutro		1	1,9	56
4422-N	8004331442203	Neutro		1	2,15	40
4432-N	8004331443217	Neutro		1	2,84	28
4400-N	8004331440001	Neutro		1	0,694	400
<b>CASSA FORATA 600x400</b>						
6007-N	8004331600702	Neutro		1	1,02	148
6010-N	8004331601006	Neutro		1	1,254	104
6013-N	8004331601303	Neutro		1	1,39	76
5800	8004331580004	Rosso	—	1	4,84	—
<b>MASTELLI</b>						
7/0110-N	8004331071106	Neutro		1	4,00	24
7/0225-N	8004331072257	Neutro		1	5,80	15
7/0275-N	8004331072752	Neutro		1	7,80	21
7/0350-N	8004331073506	Neutro		1	9,50	21
7/0500-N	8004331075005	Neutro		1	10,50	19
7/0700-N	8004331077009	Neutro		1	17,30	16
7/1000-N	8004331710005	Neutro		1	28,00	8
59/500-N	8004331595008	Neutro		1	3,00	25
59/700-N	8004331597002	Neutro		1	4,00	—
<b>IMBUTO</b>						
35-BIM	8004331035009	Bianco		6	1,09	540
10/26-BIM	8004331010266	Bianco		12	2,90	288
54/06-BIM	8004331054062	Bianco		12	0,08	—
54/08-BIM	8004331054086	Bianco		12	0,16	—
54/10-BIM	8004331054109	Bianco		12	1,39	—
54/12-BIM	8004331054123	Bianco		48	1,72	5.184
54/14-BIM	8004331054147	Bianco		36	1,80	2.592
54/16-BIM	8004331054161	Bianco		24	1,87	1.728
54/18-BIM	8004331054185	Bianco		24	2,32	1.200
54/20-BIM	8004331054208	Bianco		12	1,48	864
54/22-BIM	8004331054222	Bianco		10	1,49	720
54/24-BIM	8004331054246	Bianco		10	1,38	480
54/26-BIM	8004331054260	Bianco		10	1,80	480
54/30-BIM	8004331054307	Bianco		10	2,80	300
147/10-BIL	8004331001479	Bianco latte		12	0,18	—
147/12-BIL	8004331147122	Bianco latte		10	0,21	—
<b>SECCHIO INDUSTRIALE GRADUATO</b>						
65/12-GRI	8004331065136	Grigio	—	10	9,00	400
65/12-N	8004331065129	Neutro		10	9,00	400
65/15-GRI	8004331065167	Grigio	—	10	10,40	320
65/15-N	8004331065150	Neutro		10	10,40	320

# DATI TECNICI

## TECHNICAL DATA

### TRASPORTO LIQUIDI & INDUSTRIA ALIMENTARE

Articolo	Codice Ean	Colore	Per alim.	Imb. (Pz)	Imb. (Kg)	Pezzi pallet
65/18-GRI	8004331065198	Grigio	—	10	11,10	240
65/18-N	8004331065181	Neutro		10	11,10	240

### CARAFFA GRADUATA

6/0500-BIM	8004331605004	Bianco		36	2,98	2592
6/1000-BIM	8004331610008	Bianco		24	3,50	1152
6/2000-BIM	8004331620007	Bianco		20	3,96	560
6/3000-BIM	8004331630006	Bianco		20	5,04	560
6/5000-BIM	8004331650004	Bianco		20	7,46	360
6/0500-TS	8004331605011	Trasparente		36	2,98	2592
6/1000-TS	8004331610015	Trasparente		24	3,28	1152
6/2000-TS	8004331620014	Trasparente		20	3,96	560
6/3000-TS	8004331630013	Trasparente		20	5,04	560
6/5000-TS	8004331650011	Trasparente		20	7,54	360

### SESSOLE

31-BIM	8004331031001	Bianco		6	1,15	864
136/19-BIM	8004331136195	Bianco		48	1,53	—
136/24-BIM	8004331136249	Bianco		36	2,00	3528
136/29-BIM	8004331136294	Bianco		36	3,52	1800
136/34-BIM	8004331136348	Bianco		24	3,02	1200
136/38-BIM	8004331136386	Bianco		24	4,06	816
136/42-BIM	8004331136423	Bianco		24	5,78	672

### CASALINGHI

Articolo	Codice Ean	Colore	Per alim.	Imb. (Pz)	Imb. (Kg)	Pezzi pallet
<b>BAGNI QUADRI</b>						
21/30-AZP	8004331021316	Azzurro	—	10	4,28	600
21/30-N	8004331021309	Neutro		10	4,28	600
21/32-AZP	8004331021330	Azzurro	—	10	5,18	720
21/32-N	8004331021323	Neutro		10	5,18	720
21/34-AZP	8004331021354	Azzurro	—	10	5,50	720
21/34-N	8004331021347	Neutro		10	5,50	720

### CATINI

52/24-BIM	8004331052242	Bianco		25	2,00	—
52/26-BIM	8004331052266	Bianco		25	2,50	—
52/28-BIM	8004331052280	Bianco		25	3,00	—
52/30-BIM	8004331052303	Bianco		25	3,30	—
52/32-BIM	8004331052327	Bianco		25	4,30	—
52/34-BIM	8004331052341	Bianco		25	5,30	—
52/36-BIM	8004331052365	Bianco		25	5,80	—
52/38-BIM	8004331052389	Bianco		25	6,80	—

### BAGNI TONDI

41/32-AZP	8004331041338	Azzurro	—	10	3,90	—
41/32-N	8004331041321	Neutro		10	3,90	—

41/34-AZP	8004331041352	Azzurro	—	10	4,40	—
41/34-N	8004331041345	Neutro		10	4,40	—
41/36-AZP	8004331041376	Azzurro	—	10	4,84	—
41/36-N	8004331041369	Neutro		10	4,84	—
41/40-AZP	8004331041413	Azzurro	—	10	6,24	—
41/40-N	8004331041406	Neutro		10	6,24	—
41/45-AZP	8004331041468	Azzurro	—	5	4,06	—
41/45-N	8004331041451	Neutro		5	4,06	—
41/50-AZP	8004331041512	Azzurro	—	5	5,25	—
41/50-N	8004331041505	Neutro		5	5,25	—

### BAGNI OVALI

47/45-AZP	8004331047460	Azzurro	—	5	3,37	350
47/45-N	8004331047453	Neutro		5	3,37	350
47/50-AZP	8004331047514	Azzurro	—	5	4,72	250
47/50-N	8004331047507	Neutro		5	4,72	250
47/55-AZP	8004331047569	Azzurro	—	5	6,12	250
47/55-N	8004331047552	Neutro		5	6,12	250
47/60-AZP	8004331047613	Azzurro	—	5	8,20	135
47/60-N	8004331047606	Neutro		5	8,20	135
47/65-AZP	8004331047668	Azzurro	—	5	8,85	105
47/65-N	8004331047651	Neutro		5	8,85	105
47/70-AZP	8004331047712	Azzurro	—	5	10,80	120
47/70-N	8004331047705	Neutro		5	10,80	120
47/80-AZP	8004331047811	Azzurro	—	5	13,62	80
47/80-N	8004331047804	Neutro		5	13,62	80

### MASTELLI 3 MANICI

82/45-AZP	8004331082461	Azzurro	—	5	7,80	180
82/45-N	8004331082454	Neutro		5	7,80	180
82/50-AZP	8004331082515	Azzurro	—	5	10,40	120
82/50-N	8004331082508	Neutro		5	10,40	120
82/55-AZP	8004331082560	Azzurro	—	5	12,51	60
82/55-N	8004331082553	Neutro		5	12,51	60
82/60-AZP	8004331082614	Azzurro	—	5	15,45	60
82/60-N	8004331082607	Neutro		5	15,45	60
82/65-AZP	8004331082669	Azzurro	—	5	19,63	50
82/65-N	8004331082652	Neutro		5	19,63	50
82/70-AZP	8004331082713	Azzurro	—	5	22,77	50
82/70-N	8004331082706	Neutro		5	22,77	50

### SECCHII NORMALI GRADUATI

39/07-AZP	8004331039175	Azzurro	—	10	4,20	750
39/07-N	8004331039076	Neutro		10	4,20	750
39/09-AZP	8004331039199	Azzurro	—	10	4,50	720
39/09-N	8004331039090	Neutro		10	4,50	720
39/12-AZP	8004331039137	Azzurro	—	10	6,00	720
39/12-N	8004331039120	Neutro		10	6,00	720
39/15-AZP	8004331039168	Azzurro	—	10	7,30	480
39/15-N	8004331039151	Neutro		10	7,30	480

# DATI TECNICI

## TECHNICAL DATA

CASALINGHI						
Articolo	Codice Ean	Colore	Per alim.	Imb. (Pz)	Imb. (Kg)	Pezzi pallet
<b>SECCHII CON BECCO GRADUATI</b>						
42/09-AZP	8004331042106	Azzurro	—	10	6,00	600
42/09-N	8004331042090	Neutro	☞	10	6,00	600
42/12-AZP	8004331042137	Azzurro	—	10	7,30	600
42/12-N	8004331042120	Neutro	☞	10	7,30	600
42/15-AZP	8004331042168	Azzurro	—	10	8,70	400
42/15-N	8004331042151	Neutro	☞	10	8,70	400
<b>SCOLAPASTA</b>						
109/22-BIM	8004331109229	Bianco	☞	24	3,14	—
109/26-BIM	8004331109267	Bianco	☞	24	4,89	672

109/30-BIM	8004331109304	Bianco	☞	24	5,49	672
12-BIM	8004331012017	Bianco	☞	48	5,70	1344
<b>INSALATIERE</b>						
50/16-BIM	8004331050163	Bianco	☞	36	2,26	3456
50/18-BIM	8004331050187	Bianco	☞	24	1,94	1728
50/20-BIM	8004331050200	Bianco	☞	24	2,73	1728
50/22-BIM	8004331050224	Bianco	☞	24	3,40	1152
50/24-BIM	8004331050248	Bianco	☞	24	3,92	1152
50/26-BIM	8004331050262	Bianco	☞	12	1,76	864
50/28-BIM	8004331050286	Bianco	☞	12	2,37	576
50/30-BIM	8004331050309	Bianco	☞	12	2,94	576
50/32-BIM	8004331050323	Bianco	☞	12	3,20	—
50/34-BIM	8004331050347	Bianco	☞	12	3,88	—

# INFORMAZIONI

## INFORMATION

I colori riprodotti hanno valore indicativo.

Le misure indicate hanno una tolleranza di  $\pm 2$  mm.

I colori ed i modelli potranno subire variazioni senza preavviso.

È possibile fornire per quantità e prezzi da stabilire: prodotti in colori fuori catalogo; prodotti in materiale autoestinguente a norma UL 94; prodotti personalizzati.

Per impieghi diversi da quelli tradizionali si suggerisce di chiedere esplicite indicazioni.

*The reproduced colours have an indicative value.*

*The above-cited dimensions have a tolerance of  $\pm 2$  mm.*

*Colours and models can be subject to change without warning.*

*It is possible to supply the following in individually arranged quantities and prices: Goods in colours not in catalogue; Goods in self extinguishing materials conforming to the norms UL 94; Personalized products.*

*For specific and different uses other than those listed it is suggested to contact the company directly.*



# SERVIZIO CLIENTI

*CUSTOMER SERVICE*

• MOBIL PLASTIC offre un completo servizio di informazioni attraverso il suo Ufficio Commerciale e Marketing. Un contatto diretto, per informazioni e richieste di cataloghi, si può avere anche attraverso la e-mail [info@mobilplastic.it](mailto:info@mobilplastic.it) e l'accesso al sito Internet [www.mobilplastic.it](http://www.mobilplastic.it)

• *MOBIL PLASTIC offers a complete information service by means of the Sales and Marketing Department. You can contact the company directly for information and catalogues by e-mail [info@mobilplastic.it](mailto:info@mobilplastic.it) and Internet Web site [www.mobilplastic.it](http://www.mobilplastic.it)*

servizio  
clienti



Tel. 0039 0384 674692

e-mail



[info@mobilplastic.it](mailto:info@mobilplastic.it)



internet

[www.mobilplastic.it](http://www.mobilplastic.it)

# Mobil Plastic®





# NOTE

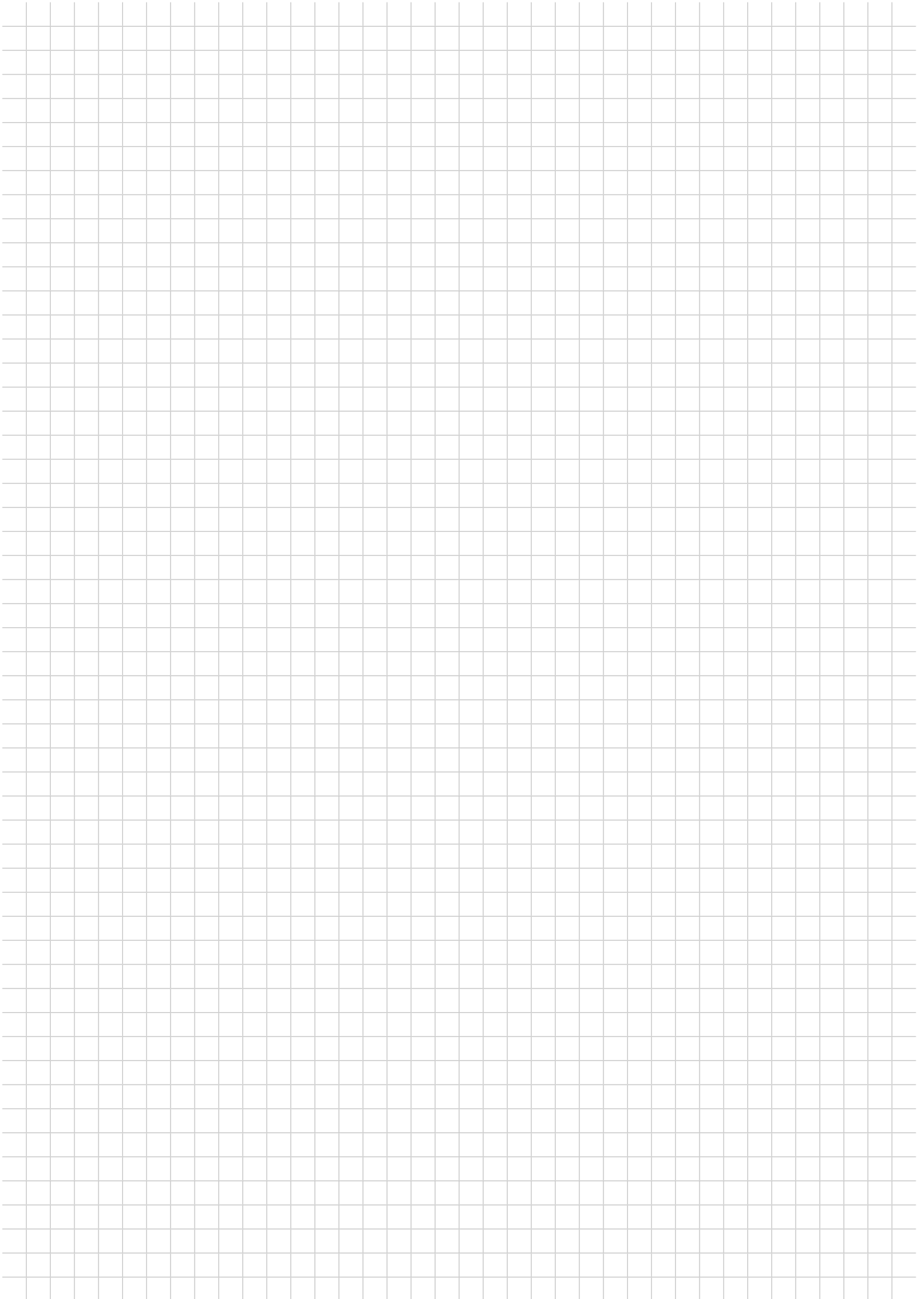

**Mobil Plastic®**



[www.mobilplastic.it](http://www.mobilplastic.it)



**MOBIL PLASTIC S.P.A.** - Via Robbio, 31 - 27030 CONFENZA (PV)  
Tel. 0384.674692 (4 linee r. a.) - Fax: 0384.674696 E-Mail: [info@mobilplastic.it](mailto:info@mobilplastic.it)